

**TWC**

\* По заказу мы можем изготовить с углом 0,5°  
\* Hole inclination 0,5° on request

Мар: 1.8159  
55 ± 2 HRC

d2	d	k	b	d1	l	NR KAT.
12	28	13	11	2,5	22	TWC-122522
					27	TWC-122527
					36	TWC-122536
					46	TWC-122546
					56	TWC-123556
				3,5	22	TWC-123522
					27	TWC-123527
					36	TWC-123536
					46	TWC-123546
					56	TWC-123556
18	38	18	11	3	27	TWC-183027
					36	TWC-183036
					46	TWC-183046

d2	d	k	b	d1	l	NR KAT.
18	38	18	15	3	56	TWC-183056
					76	TWC-183076
					96	TWC-183096
					116	TWC-1830116
					116	TWC-1830116
				4	27	TWC-184027
					36	TWC-184036
					46	TWC-184046
					56	TWC-184056
					76	TWC-184076
18	38	18	15	3	96	TWC-184096
					116	TWC-1840116
					116	TWC-1840116

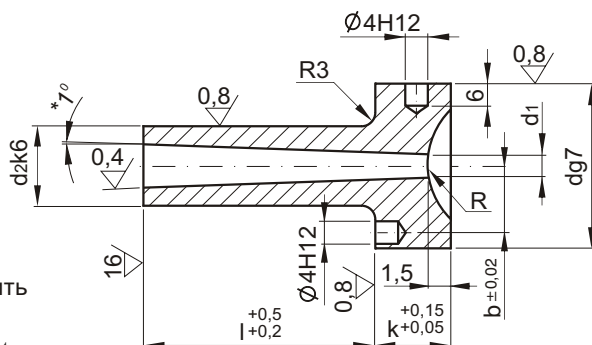

**TWD**

\* По заказу мы можем изготовить с углом 0,5°  
\* Hole inclination 0,5° on request

Мар: 1.8159  
55 ± 2 HRC

R=15,5						
d2	d	k	b	d1	l	Ном. Кат.
12	28	13	11	2,5	22	TWD-122522-15,5
					27	TWD-122527-15,5
					36	TWD-122536-15,5
					46	TWD-122546-15,5
					56	TWD-123556-15,5
				3,5	22	TWD-123522-15,5
					27	TWD-123527-15,5
					36	TWD-123536-15,5
					46	TWD-123546-15,5
					56	TWD-123556-15,5
18	38	18	15	3	27	TWD-183027-15,5
					36	TWD-183036-15,5
					46	TWD-183046-15,5
					56	TWD-183056-15,5
					76	TWD-183076-15,5
					96	TWD-183096-15,5
				116	TWD-1830116-15,5	
				4	27	TWD-184027-15,5
					36	TWD-184036-15,5
					46	TWD-184046-15,5
					56	TWD-184056-15,5
					76	TWD-184076-15,5
					96	TWD-184096-15,5
116	TWD-1840116-15,5					

R=40						
d2	d	k	b	d1	l	Ном. Кат.
12	28	13	11	2,5	22	TWD-122522-40
					27	TWD-122527-40
					36	TWD-122536-40
					46	TWD-122546-40
					56	TWD-123556-40
				3,5	22	TWD-123522-40
					27	TWD-123527-40
					36	TWD-123536-40
					46	TWD-123546-40
					56	TWD-123556-40
18	38	18	15	3	27	TWD-183027-40
					36	TWD-183036-40
					46	TWD-183046-40
					56	TWD-183056-40
					76	TWD-183076-40
					96	TWD-183096-40
				116	TWD-1830116-40	
				4	27	TWD-184027-40
					36	TWD-184036-40
					46	TWD-184046-40
					56	TWD-184056-40
					76	TWD-184076-40
					96	TWD-184096-40
116	TWD-1840116-40					