

FCPK
BYTÓW

®

КВОТА

ул. Подольская, 46, 46006, г. Тернополь, Украина
+38 0352 43-49-25 kvotatr@gmail.com
www.kvota.com.ua



Punches and Dies
Stemple i Matryce

Contents

SPIS TRE CI

	Symbol	Page Strona	
Standard Punches <i>Stemple standardowe</i>	MT, MR, MF, MW, MI	M.5	
Slug Ejector Punches <i>Stemple z wyrzutnikiem</i>	MET, MER, MEF, MEW, MEL	M.6	
Punch Blanks <i>Półfabrykaty stempli</i>	M	M.7	
Slug Ejector Punch Blanks <i>Półfabrykaty stempli z wyrzutnikiem</i>	MPE	M.8	
Pilot Points <i>Piloty z odsadzeniem</i>	MP	M.9	
Parallel Pilots <i>Piloty proste</i>	MPP	M.10	
Angular Pilot Points <i>Piloty z odsadzeniem -ko cówka sto kowa</i>	AMP	M.11	
Angular Parallel Pilots <i>Piloty proste -ko cówka sto kowa</i>	AMPP	M.12	
Heavy Duty Punch <i>Stemple do wysokich obci e</i>	HMT, HMR, HMF, HMW, HML	M.13	
Heavy Duty Ejector Punch <i>Stemple z wyrzutnikiem do wysokich obci e</i>	HEMT, HEMR, HEMF, HEMW, HEML	M.14	
Heavy Duty Punch Blanks (solid, ejector) <i>Półfabrykaty stempli do wysokich obci e (zwykle, z wyrzutnikiem)</i>	HM, HEM	M.15	
ISO Round / Shaped Punches <i>Stemple ISO</i>	PT, PR, PF, PW, PL	M.16	
ISO Round / Shaped Slug Ejector Punches <i>Stemple z wyrzutnikiem ISO</i>	PET, PER, PEF, PEW, PEL	M.17	
ISO Punch Blanks <i>Półfabrykaty stempli ISO</i>	PB	M.18	
Standard Center Dowel Punches <i>Stemple z otworem na kótek ustalaj cy</i>	LMT, LMR, LMF, LMW, LML	M.19	
Slug Ejector Center Dowel Punches <i>Stemple z wyrzutnikiem z otworem na kótek ustalaj cy</i>	LMET, LMER, LMEF, LMEW, LMEL	M.20	
Standard Center Dowel Punch Blanks <i>Półfabrykaty stempli z otworem na kótek ustalaj cy</i>	LM	M.21	
Slug Ejector Center Dowel Punch Blanks <i>Półfabrykaty stempli z wyrzutnikiem z otworem na kótek ustalaj cy</i>	LME	M.22	
Headed Punch Retainer (Shaped) <i>Oprawki do stempli z główek (kształtowe)</i>	HHR	M.23	
Headed Punch Retainer (Round) <i>Oprawki do stempli z główek (okr gte)</i>	HHS	M.24	
Ball-Lock Retainers <i>Oprawki do stempli szybkowymiennych</i>	AWL, AWH	M.25	
Ball Lock Multi Hole Retainer <i>Wielootworowe oprawki do stempli szybkowymiennych</i>	WML, AWMH	M.26	
Retainer Strippers <i>Uretanowe tuleje zdzieraj ce</i>	AWR, AWS	M.27	
Ball Lock Punch Blanks <i>Półfabrykaty stempli szybkowymiennych</i>	LAW, LEW	M.28	
Light Duty Ball Lock Punch Shapes <i>Stemple szybkowymienne do niskich obci e</i>	LBT, LBR, LBF, LBW, LBL	M.29	
Heavy Duty Ball Lock Punch Shapes <i>Stemple szybkowymienne do wysokich obci e</i>	HBT, HBR, HBF, HBW, HBL	M.30	
Light Duty Ball Lock Slug Ejector Punches <i>Stemple szybkowymienne z wyrzutnikiem do niskich obci e</i>	LEBT, LEBR, LEBF, LEBW, LEBL	M.31	
Heavy Duty Ball Lock Slug Ejector Punches <i>Stemple szybkowymienne z wyrzutnikiem do wysokich obci e</i>	HEBT, HEBR, HEBF, HEBW, HEBL	M.32	
Light Duty Ball-Lock Punches - Point Larger than Shank <i>Stemple szybkowymienne do niskich obci e - ko cówka wi ksza ni trzon</i>	ALT, ALR, ALF, ALW, ALL	M.33	
Heavy Duty Ball-Lock Punches - Point Larger than Shank <i>Stemple szybkowymienne do wysokich obci e - ko cówka wi ksza ni trzon</i>	AHT, AHR, AHF, AHW, AHL	M.34	
Light Duty Ejector Ball-Lock Punches - Point Larger than Shank <i>Stemple szybkowymienne z wyrzutnikiem do niskich obci e - ko cówka wi ksza ni trzon</i>	AELT, AELR, AELF, AELW, AELL	M.35	
Heavy Duty Ejector Ball-Lock Punches - Point Larger than Shank <i>Stemple szybkowymienne z wyrzutnikiem do wysokich obci e - ko cówka wi ksza ni trzon</i>	AEHT, AEHR, AEHF, AEHW, AEHL	M.36	
Ball Lock Pilot Points <i>Piloty z odsadzeniem, szybkowymienne</i>	LBP, HBP	M.37	
Ball Lock Parallel Pilots <i>Piloty proste szybkowymienne</i>	LBPP, HBPP	M.38	

Stemple i matryce specjalne

Special Punches and Dies

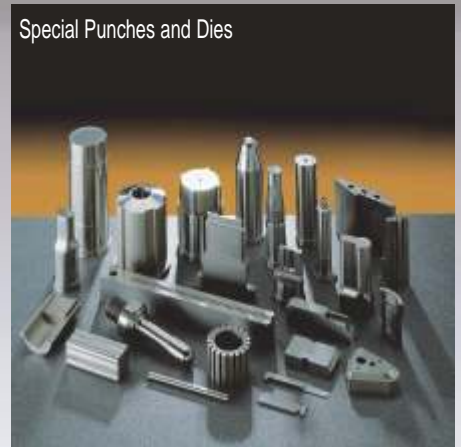

Oprawki, stemple i matryce szybkowymienne

Ball Lock Retainers Punches and Dies

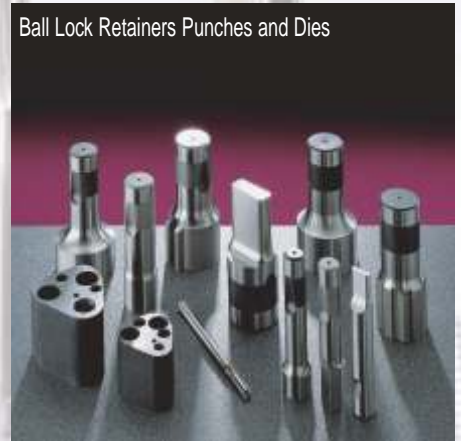

Stemple i matryce powlekane

Coated Punches and Dies

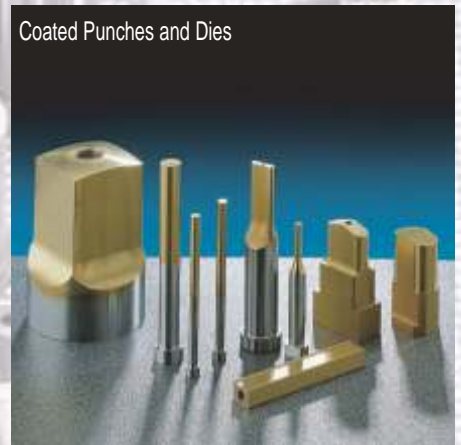

Standardowe stemple i matryce

Standard Headed Punches and Dies

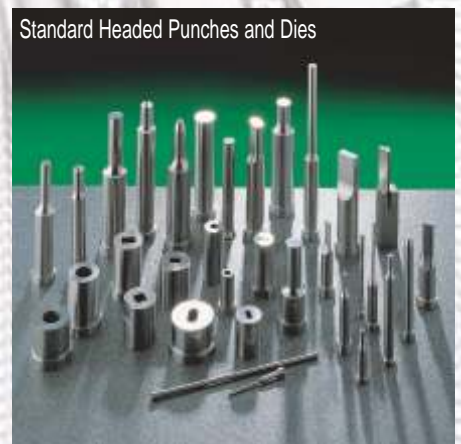

Standardowe stemple i matryce

Standard Headed Punches and Dies



Stemple i matryce powlekane

Coated Punches and Dies

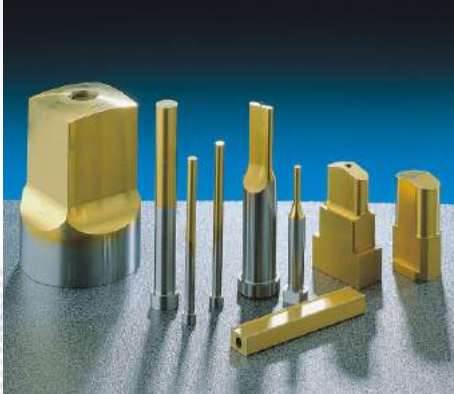

Oprawki, stemple i matryce szybkowymienne



























Ball Lock Retainers Punches and Dies



Stemple i matryce specjalne

Special Punches and Dies



Ball Lock Angular Pilot Points <i>Piloty z odsadzeniem z końcówką stożkową szybkowymienne</i>	HBAPP, LBAPP	M.39	
Ball Lock Angular Parallel Pilots <i>Piloty proste z końcówką stożkową szybkowymienne</i>	LBAP, HBAP	M.40	
Light Duty Ball Lock Dies <i>Tuleje tnące szybkowymienne do niskich obciążeń</i>	LBDT, LBDR, LBDF, LBDW, LBDL	M.41	
Light Duty Ball Lock Die Blanks <i>Tuleje tnące szybkowymienne do niskich obciążeń do obróbki EDM</i>	LBDB	M.42	
Stripper Bushes <i>Tuleje zdzierające</i>	MSD, MS, MSU	M.43	
Standard Drawing Punches <i>Stemple ciągowe</i>		M.44	
Plunged Hole Punches <i>Stemple do wytłaczania otworów do gwintowania</i>	PH	M.45	
Solid Any Size Punches <i>Stemple - dowolne wymiary</i>	MAP	M.46	
Countersunk Headed Punches <i>Stemple z łbem stożkowym</i>	DAT, DAR, DAF, DAW, DAL	M.47	
Punches type ND <i>Stemple typ ND</i>	ND	M.48-M.49	
Punches type NDA <i>Stemple typ NDA</i>	NDA	M.50-M.51	
Die Bushes <i>Tuleje tnące</i>	DS02	M.52	
Punch Quills Metric <i>Oprawki stemplowe</i>	MPQ	M.53	
Slug Ejector Pins <i>Wyrzutniki</i>	EPO	M.53	
Slug Ejector Springs <i>Sprężyny wyrzutnika</i>	ES	M.53	
Clamping Die Bush Shape <i>Tuleje tnące kształtowe z elementem mocującym</i>	SMD	M.54	
Clamping Die Bush Round <i>Tuleje tnące okrągłe z elementem mocującym</i>	SMDP	M.55	
Die Bush-E.D.M Die Blanks <i>Półfabrykaty tulei tnących do obróbki EDM</i>	MDB, MDHB	M.56	
Die Bush-Round Parallel Recess <i>Tuleje tnące okrągłe z wybiegiem cylindrycznym</i>	MDP, MDHP	M.57	
Die Bush- Round Taper Recess <i>Tuleje tnące okrągłe z wybiegiem stożkowym</i>	MDT, MDHT	M.58	
Die Bush-E.D.M <i>Tuleje tnące kształtowe</i>	MDR, MDF, MDW, MDL, MDHR, MDHF, MDHW, MDHL	M.59	
Headed / Headless Round Dies Counter Bore Recess <i>Tuleje tnące okrągłe ISO</i>	DDP, DDHP	M.60	
Headed / Headless Shaped Dies Counter Bore Recess <i>Tuleje tnące kształtowe ISO</i>	DDR, DDF, DDW, DDL, DDHR, DDHF, DDHW, DDHL	M.61	
Non Standard Punch and Dies <i>Niestandardowe stemple i matryce</i>		M.62	
Plan View of Die / Through Head of Punch <i>Niestandardowe stemple i matryce</i>		M.63	
Die Alternatives <i>Tuleje tnące - opcje</i>	AL, AHD, AHT, ABD	M.64	
Standard Body Flat Locations for Punches, Dies and Strippers <i>Standardowe sposoby zabezpieczenia przed obrotem dla stempli i matryc</i>		M.65	
Standard Locations for Punches, Strippers and Dies <i>Standardowe sposoby zabezpieczenia przed obrotem dla stempli i matryc</i>		M.66	
Tolerance Tables <i>Tolerancje</i>		M.67	
Ball Lock Release Tool <i>Narzędzia do oprawek szybkomocujących</i>	818038, 818046, 269999	M.68	
How To Order <i>Jak zamawiać</i>		M.69	
Blade Punches <i>Stemple nożowe</i>		M.70	

Our products are available in / Dostępne materiały:

1.3343 (M2) For applications where high speed piercing, highly abrasive materials such as stainless steel, **our preferred material choice**. / Stal szybkoobrotowa bardzo odporna na ścieranie, doskonała do wykrawiania materiałów takich, jak np., stal nierdzewna, **standardowy materiał naszych wyrobów**.

1.2363 (A2) Tough, resistant to abrasion, an excellent steel for punch & die applications. / Twarda, odporna na obciążenia dynamiczne stal, wytrzymała na ścieranie, doskonały materiał na stemple i matryce.

1.2379 (D2) A good quality tool steel for punching and forming / Dobrej jakości stal narzędziowa do tłoczenia i formowania.

PM-Powder A special high speed steel manufactured by a powder metallurgy method.

Tool Steel A combination of high wear resistance and toughness make it a good choice for

(ASP 23, improved quality / Specjalna stal szybkoobrotowa wykonana metodą metalurgii proszków charakteryzująca się wysoką wytrzymałością na ścieranie i wysoką twardością.

BENEFITS OF RECOMMENDED COATINGS / KORZYŚCI JAKIE DAJĄ, OFEROWANE POWŁOKI:

*Longer service life & higher press stroke rates / Przedłużona żywotność stempli i szybsze skoki prasy.

*Decreased down time to replace worn parts / Rzadsze zatrzymania w celu wymiany zużytych części.

*Less lubricants, thus making them more environmentally friendly / Mniejsza potrzeba smarowania - z korzyścią dla środowiska.

*Prevention Of Cold welding / Zapobieganie zjawisku zgrzewania na zimno.

*Minimises friction thus requiring less stripping pressure / Minimalizuje tarcie i tym samym wymagany nacisk zdzieraka jest mniejszy.



Coating type Rodzaj powłoki	Titanium Nitride Azotek tytanu TiN	Titanium Carbonitride Węglik azotek tytanu TiCN	Chromium Nitride Azotek chromu CrN	Titanium Aluminium Nitride Azotek Tytanu i Aluminium TiAlN
Color Kolor powłoki	Gold Złoty	Blue/Grey Niebiesko-szary	Silver/Grey Srebrno-szary	Blue/Black Niebiesko-czarny
Microhardness (HV) Twardość powłoki (HV)	2300	3000	2000	3000
Coefficient of friction against steel Współczynnik tarcia względem stali	0,4	0,4	0,4	0,4
Coating Thickness Grubość powłoki	3-4 microns	3-4 microns	3-4 microns	1-4 microns
Maximum working temperature Maks. temp. robocza	600°C	400°C	700°C	800°C
Characteristics Charakterystyka	Good balance of properties Doskonały zestaw właściwości	High hardness, good wear resistance, enhanced toughness Wysoka twardość i odporność na zużycie, dobra wiązkość	Resistance to corrosion and adhesive wear, good for non ferrous applications Odporność na korozję i zużycie adhezyjne, idealna do metali nieelastycznych	High hardness, good wear resistance, enhanced toughness Wysoka twardość i odporność na zużycie, dobra wiązkość
Applications Zastosowanie	Cutting, forming, punching, broaching Cięcie, formowanie, wykrawianie, przecięganie	Cutting, forming, punching, broaching Cięcie, formowanie, wykrawianie, przecięganie	Cutting, forming, punching Cięcie, formowanie, wykrawianie	Cutting, forming, punching, broaching Cięcie, formowanie, wykrawianie, przecięganie

To coat any punch & die the minimal material spec must be HSS 1.3343 (M2)

Powysze powłoki stosowane są tylko na wyrobach ze stali szybkoobrotowej 1.3343 (M2) lub lepszej

Example order- Przykładowe zamówienie:

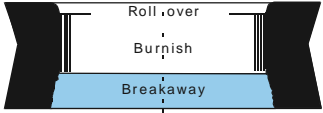
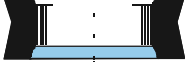
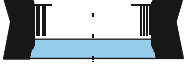
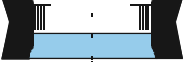
MT6B 5,5 x 70 HSS TiN

Hole Type & Variation Dependand on Clearance <i>Rodzaje otworów w zaleznosci od luzu</i>	Tight Clearance <i>Minimalny luz</i>	Normal Clearance <i>Normalny luz</i>	Optimum Clearance <i>Optymalny luz</i>	Maximum Clearance (Extended tool life) <i>Maksymalny luz (wi ksza trwało narz dzia)</i>
				
			Use with ejector punches Zaleca si stosowanie stempli z wyrzutnikiem	
Aluminium, Hard <i>Twarde aluminium</i>	1 - 2%	4 - 8%	12 - 15%	16 - 20%
Aluminium, Soft <i>Mi kkie aluminium</i>	1 - 2%	10 - 12%	18 - 20%	25 - 28%
Brass, 1/2 Hard <i>Mosi dz półtwardy</i>	1 - 3%	4 - 6%	12 - 16%	16 - 20%
Brass, Annealed <i>Mosi dz wy arzony</i>	3 - 5%	6 - 10%	12 - 16%	18 - 22%
Bronze, 1/2 Hard <i>Br z, półtwardy</i>	1 - 3%	7 - 10%	20 - 24%	25 - 27%
Copper, 1/2 Hard <i>Mied , półtwarda</i>	2 - 4%	6 - 10%	12 - 16%	18 - 22%
Copper, Annealed <i>Mied , wy arzona</i>	1 - 2%	4 - 8%	10 - 14%	16 - 18%
Magnesium <i>Magnez</i>	1 - 2%	3 - 6%	7 - 9%	10 - 14%
Stainless, Annealed <i>Stal nierdzewna, wy arzona</i>	2 - 4%	6 - 10%	18 - 22%	25 - 27%
Steel, High Carbon <i>Stal wysokow glowa</i>	5 - 10%	22 - 25%	26 - 32%	33 - 36%
Steel, Low Carbon <i>Stal niskow glowa</i>	2 - 4%	10 - 14%	16 - 20%	16 - 23%

All above clearances are total % allowance of material thickness
Zamieszczone w tabeli wielko ci luzu stanowi % grubo ci wykrawanego materiału

Formula for Calculating Blanking Pressure?

Obliczanie siły nacisku przy wykrawaniu

Blanking Pressure in tons: $P = LTS \div 2000$

Siła nacisku w tonach

L = Length of Cut – Długo wyci cia

T = Thickness of material – Grubo materiału

S = Shear Strength of material – Wytrzymało materiału na cinanie

Stripping Pressure

Stripping pressure will not normally exceed 10% of Blanking pressure under normal conditions.

W normalnych warunkach siła zdzieraj ca nie przekracza 10% siły nacisku

	Material Group <i>Grupa materiałów</i>	High Carbon Steel, Hard Bronze, Spring Steel <i>Stal wysokow glowa, twardy br z, stal spr ynowa</i>	Stainless Steel, Medium Carbon Steel <i>Stal nierdzewna, stal redniow glowa</i>	Low Carbon Steel, Hard Aluminium, Hard Brass <i>Stal niskow glowa, twarde aluminium, twardy mosi d</i>	Soft Brass, Aluminium, Copper <i>Mi kki mosi d , aluminium, mied</i>
Shear Strength Wytrzymało na cinanie	Kg/cm ²	7000 – 14000	4200 – 7000	2800 – 4200	2100 – 2800

These are guide lines only. We accept no liability.

Powy sze informacje s jedynie wskazówkami, za które nie mo emy bra odpowiedzialno ci.

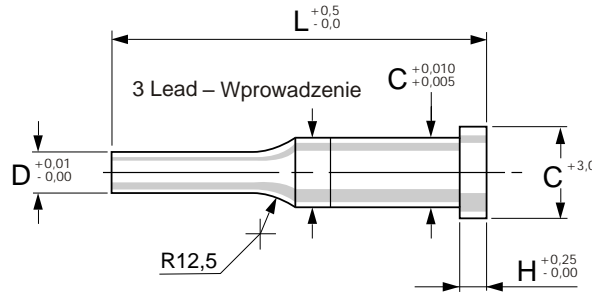

Headless punches available— Stemple bez główki na życzenie
 Overall length up to 125mm— Całkowita długość do 125mm
 Any alternative dimensions to the above can be specified— Dostępne są te inne wymiary nielokalne powyżej.
 Available with dowel location in head— Dostępna jest wersja z otworem na kołek ustalającymcy w główce.
 Forged head available— Stemple z kutygłówkąna życzenie.

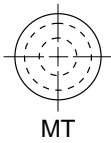
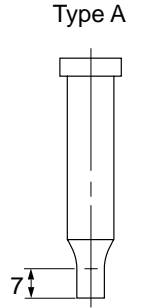

MT

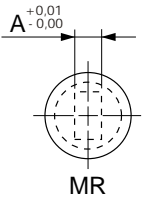

MR

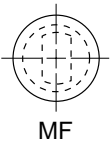

MF

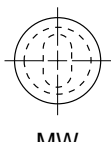

MW

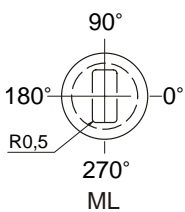

ML

Symbol							
MT	MR	MF	MW	ML	C	H	Min. D
MT3	MR3	MF3	MW3	ML3	3	4,2*	1,5
MT4	MR4	MF4	MW4	ML4	4	4,2*	1,5
MT5	MR5	MF5	MW5	ML5	5	4,2*	1,5
MT6	MR6	MF6	MW6	ML6	6	5,0	1,5
MT7	MR7	MF7	MW7	ML7	7	5,0	1,5
MT8	MR8	MF8	MW8	ML8	8	5,0	2,3
MT10	MR10	MF10	MW10	ML10	10	5,0	3,2
MT12	MR12	MF12	MW12	ML12	12	5,0	3,2
MT13	MR13	MF13	MW13	ML13	13	5,0	3,2
MT14	MR14	MF14	MW14	ML14	14	5,0	4,0
MT16	MR16	MF16	MW16	ML16	16	5,0	4,8
MT18	MR18	MF18	MW18	ML18	18	5,0	5,0
MT19	MR19	MF19	MW19	ML19	19	6,4*	5,0
MT20	MR20	MF20	MW20	ML20	20	6,4*	5,0
MT22	MR22	MF22	MW22	ML22	22	6,4*	5,0
MT25	MR25	MF25	MW25	ML25	25	6,4*	5,0
MT28	MR28	MF28	MW28	ML28	28	6,4*	5,0
MT30	MR30	MF30	MW30	ML30	30	6,4*	5,0
MT32	MR32	MF32	MW32	ML32	32	6,4*	5,0
MT35	MR35	MF35	MW35	ML35	35	6,4*	5,0
MT40	MR40	MF40	MW40	ML40	40	6,4*	5,0
MT45	MR45	MF45	MW45	ML45	45	6,4*	5,0

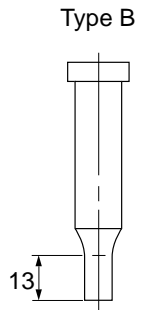

Type B

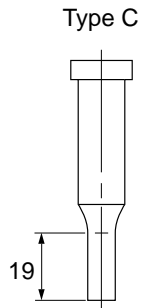

Type C

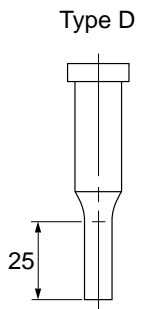

Type D

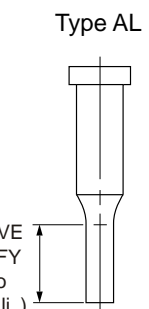

Type AL

ALTERNATIVE LENGTH SPECIFY
 – Inna długość (określić)

Example order- Przykładowe zamówienie: MT6C 3,5 60
 How to order see page M.71 - Sposób zamawiania, patrz strona M.71
 Location Flats if required (see page M.67,M.68)- Zabezpieczenie przed obrotem na życzenie (patrz strony M.67,M.68)
 * 5mm Head Thickness available- Główna o grubości 5mm na życzenie.
 Imperial sizes also available- Wszystkie wymiary dostępne także w wersji calowej.

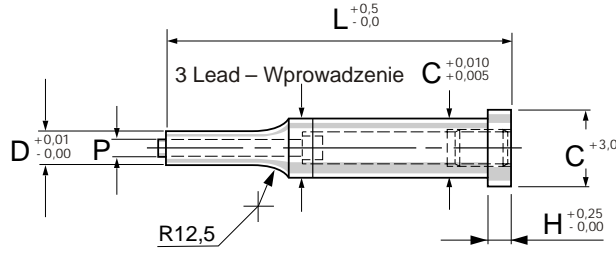

Overall length up to 100mm – Całkowita długość do 100mm
Any alternative dimensions to the above can be specified – Dostępne są te inne wymiary nielokalne powyżej.

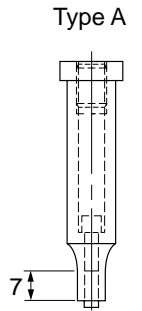

Type A

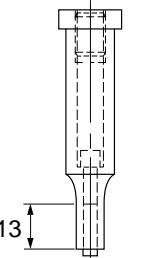

Type B

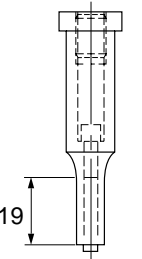

Type D

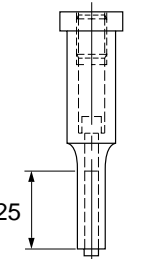

Type AL

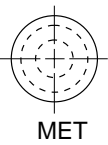

MET

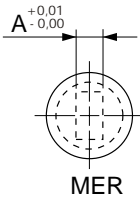

MER

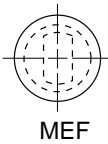

MEF

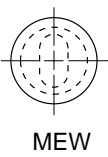

MEW

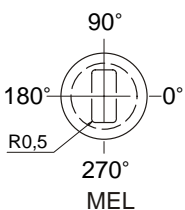

MEL

Symbol								
MET	MER	MEF	MEW	MEL	C	H	P	Min. A/D
MET5	MER5	MEF5	MEW5	MEL5	5	4,2*	0,8	2,3
MET6	MER6	MEF6	MEW6	MEL6	6	5,0	0,8	2,3
MET7	MER7	MEF7	MEW7	MEL7	7	5,0	1,0	3,0
MET8	MER8	MEF8	MEW8	MEL8	8	5,0	1,0	3,0
MET10	MER10	MEF10	MEW10	MEL10	10	5,0	1,5	4,8
MET12	MER12	MEF12	MEW12	MEL12	12	5,0	1,5	4,8
MET13	MER13	MEF13	MEW13	MEL13	13	5,0	1,5	4,8
MET14	MER14	MEF14	MEW14	MEL14	14	5,0	1,5	4,8
MET16	MER16	MEF16	MEW16	MEL16	16	5,0	2,4	5,5
MET18	MER18	MEF18	MEW18	MEL18	18	5,0	2,4	5,5
MET19	MER19	MEF19	MEW19	MEL19	19	6,4*	2,4	5,5
MET20	MER20	MEF20	MEW20	MEL20	20	6,4*	2,4	5,5
MET22	MER22	MEF22	MEW22	MEL22	22	6,4*	2,4	5,5
MET25	MER25	MEF25	MEW25	MEL25	25	6,4*	2,4	5,5
MET28	MER28	MEF28	MEW28	MEL28	28	6,4*	2,4	5,5
MET30	MER30	MEF30	MEW30	MEL30	30	6,4*	2,4	5,5
MET32	MER32	MEF32	MEW32	MEL32	32	6,4*	2,4	5,5
MET35	MER35	MEF35	MEW35	MEL35	35	6,4*	2,4	5,5
MET38	MER38	MEF38	MEW38	MEL38	38	6,4*	2,4	5,5
MET40	MER40	MEF40	MEW40	MEL40	40	6,4*	2,4	5,5
MET45	MER45	MEF45	MEW45	MEL45	45	6,4*	2,4	5,5

Example order- Przykładowe zamówienie:

MEF35D 30,0x22,0 75

MET13C 9,5 75

How to order see page M.71 - Sposób zamawiania, patrz strona M.71

Location Flats if required (see page M.67,M.68)- Zabezpieczenie przed obrotem na życzenie (patrz strony M.67,M.68)

Ejector components (see page M.54)- Elementy składowe wyrzutnika (patrz strona M.54)

* 5mm Head Thickness available- Główna o grubości 5mm na życzenie.

Imperial sizes also available- Wszystkie wymiary dostępne także w wersji calowej.

ALTERNATIVE LENGTH SPECIFY – Inna długość (określić)

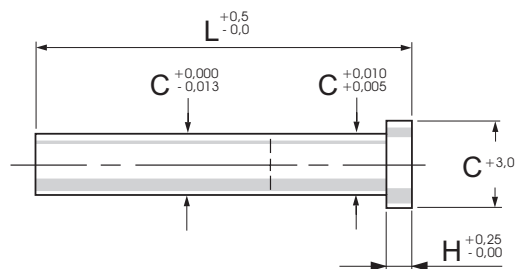

Overall length up to 125mm– Całkowita długość do 125mm
Any alternative dimensions to the above can be specified–
Dostępne są też inne wymiary niż określone powyżej.
Forged head available- Stemple z kutą główką na życzenie.

Symbol	C	H
M3	3	4,2*
M4	4	4,2*
M5	5	4,2*
M6	6	5,0
M7	7	5,0
M8	8	5,0
M10	10	5,0
M12	12	5,0
M13	13	5,0
M14	14	5,0
M16	16	5,0
M18	18	5,0
M19	19	6,4*
M20	20	6,4*
M22	22	6,4*
M25	25	6,4*
M28	28	6,4*
M30	30	6,4*
M32	32	6,4*
M35	35	6,4*
M40	40	6,4*
M45	45	6,4*

Example order- Przykładowe zamówienie:

M10 x 70

How to order see page M.71 - Sposób zamawiania, patrz strona M.71

* 5mm Head Thickness available- Główna o grubości 5mm na życzenie.

Imperial sizes also available- Wszystkie wymiary dostępne także w wersji calowej.

See page M.46 for intermediate Shank Diameters- Inne średnice trzonu na stronie M.46

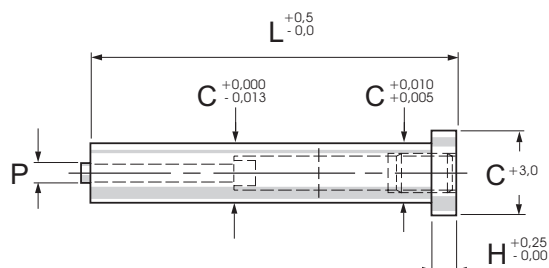

Overall length up to 100mm– Całkowita długość do 100mm
Any alternative dimensions to the above can be specified–
Dostępne są też inne wymiary niż określone powyżej.

Symbol	C	H	P
MPE01	5	4,2*	0,5
MPE05	5	4,2*	0,8
MPE06	6	5,0	0,8
MPE07	7	5,0	1,0
MPE08	8	5,0	1,0
MPE10	10	5,0	1,5
MPE12	12	5,0	1,5
MPE13	13	5,0	1,5
MPE16	16	5,0	2,4
MPE18	18	5,0	2,4
MPE19	19	6,4*	2,4
MPE20	20	6,4*	2,4
MPE22	22	6,4*	2,4
MPE25	25	6,4*	2,4
MPE28	28	6,4*	2,4
MPE30	30	6,4*	2,4
MPE32	32	6,4*	2,4
MPE35	35	6,4*	2,4
MPE40	40	6,4*	2,4

Example order- Przykładowe zamówienie:

MPE10 x 70

How to order see page M.71 - Sposób zamawiania, patrz strona M.71

* 5mm Head Thickness available- Głównka o grubości 5mm na życzenie.

Ejector component (see page M.54) - Elementy składowe wyrzutnika (patrz strona M.54)

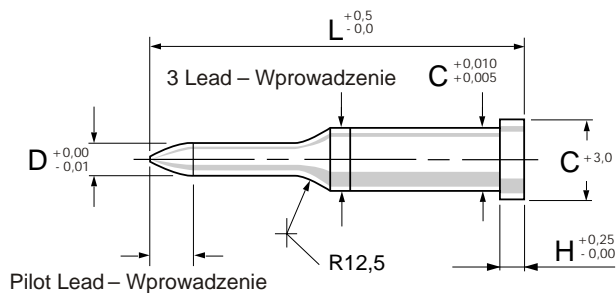

Overall length up to 125mm – Całkowita długość do 125mm
Any alternative dimensions to the above can be specified –
Dostępne są też inne wymiary niżej określone powyżej.

Type B

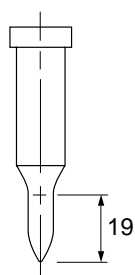

Type C

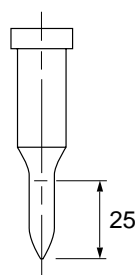

Type D

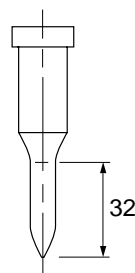

Type AL

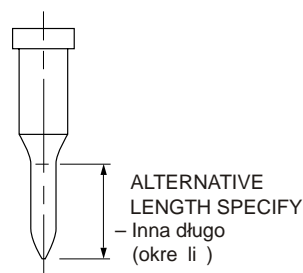

Symbol	C	H	D
MP3	3	4,2*	2,3-2,95
MP4	4	4,2*	2,3-3,95
MP5	5	4,2*	2,3-4,95
MP6	6	5,0	2,3-5,95
MP7	7	5,0	3,2-6,95
MP8	8	5,0	3,2-7,95
MP10	10	5,0	3,2-9,95
MP12	12	5,0	5,3-11,95
MP13	13	5,0	6,3-12,95
MP14	14	5,0	6,3-13,95
MP16	16	5,0	9,5-15,95
MP18	18	5,0	9,5-17,95
MP19	19	6,4*	9,5-18,95
MP20	20	6,4*	12,0-19,95
MP22	22	6,4*	15,0-21,95
MP25	25	6,4*	18,0-24,95
MP28	28	6,4*	22,0-27,95
MP30	30	6,4*	25,0-22,95
MP32	32	6,4*	27,0-31,95
MP35	35	6,4*	30,0-34,95
MP40	40	6,4*	33,0-39,95
MP45	45	6,4*	38,0-44,95

D	Pilot Lead Wprowadzenie
2,3-6,0	4
6,01-10,0	6
10,01-13,0	8
13,01-18,0	10
18,01-25,0	13
25,01-45,0	16

Example order - Przykładowe zamówienie:
MP 18C 12,0 90

How to order see page M.71 - Sposób zamawiania, patrz strona M.71

* 5mm Head Thickness available - Główna o grubości 5mm na życzenie.

Imperial sizes also available - Wszystkie wymiary dostępne także w wersji calowej.

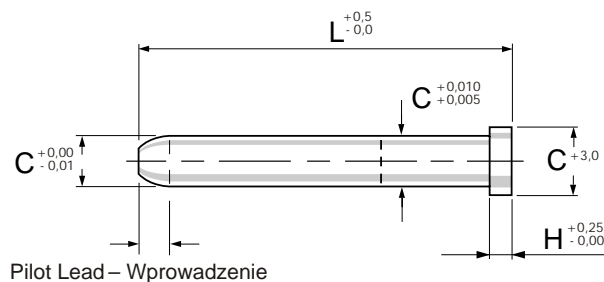

Overall length up to 125mm – Całkowita długość do 125mm
Any alternative dimensions to the above can be specified –
Dostępne są też inne wymiary niż określone powyżej.

Symbol	C	H
MPP3	3	4,2*
MPP4	4	4,2*
MPP5	5	4,2*
MPP6	6	5,0
MPP7	7	5,0
MPP8	8	5,0
MPP10	10	5,0
MPP12	12	5,0
MPP13	13	5,0
MPP14	14	5,0
MPP16	16	5,0
MPP18	18	5,0
MPP19	19	6,4*
MPP20	20	6,4*
MPP22	22	6,4*
MPP25	25	6,4*
MPP28	28	6,4*
MPP30	30	6,4*
MPP32	32	6,4*
MPP35	35	6,4*
MPP40	40	6,4*
MPP45	45	6,4*

D	Pilot Lead Wprowadzenie
2,3-6,0	4
6,01-10,0	6
10,01-13,0	8
13,01-18,0	10
18,01-25,0	13
25,01-45,0	16

Example order- Przykładowe zamówienie:
MPP 16 x 90

How to order see page M.71 - Sposób zamawiania, patrz strona M.71

* 5mm Head Thickness available- Główka o grubości 5mm na życzenie.

Imperial sizes also available- Wszystkie wymiary dostępne także w wersji calowej.

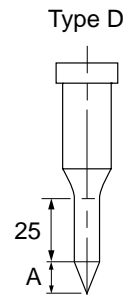
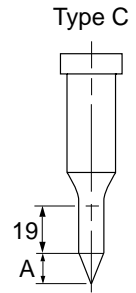
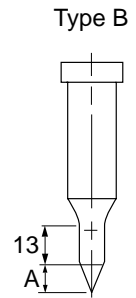
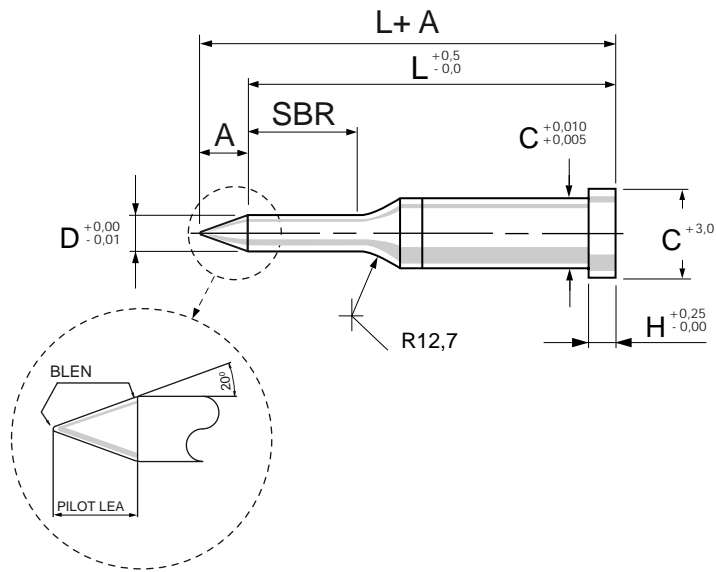

Symbol	C	H	D	A
AMP10	10	5,0	4,5-10,0	8
AMP13	13	5,0	6,0-13,0	10
AMP16	16	5,0	10,0-16,0	15
AMP20	20	6,4*	13,5-20,0	20
AMP25	25	6,4*	17,5-25,0	25
AMP32	32	6,4*	20,5-32,0	30

Type AL

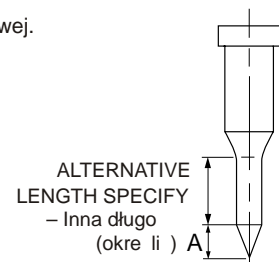

Example order- Przykładowe zamówienie:

AMP16B 13,5x100

How to order see page M.71 - Sposób zamawiania, patrz strona M.71

* Alternative Head Thickness available- Inna grubość głowki na życzenie.

Imperial sizes also available- Wszystkie wymiary dostępne także w wersji calowej.

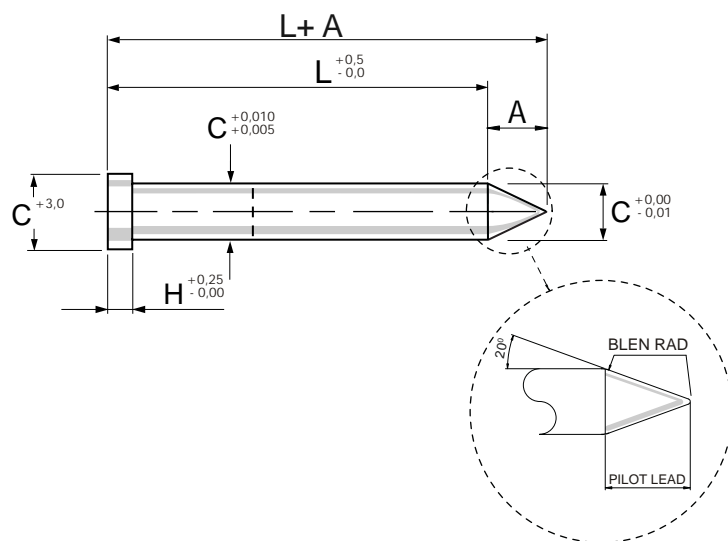

Symbol	C	H	A
AMPP3	3	4,2*	6,0
AMPP4	4	4,2*	6,0
AMPP5	5	4,2*	8,0
AMPP6	6	5,0	8,0
AMPP7	7	5,0	8,0
AMPP8	8	5,0	8,0
AMPP10	10	5,0	10,0
AMPP12	12	5,0	10,0
AMPP13	13	5,0	15,0
AMPP14	14	5,0	15,0
AMPP16	16	5,0	20,0
AMPP18	18	5,0	20,0
AMPP19	19	6,4*	25,0
AMPP20	20	6,4*	25,0
AMPP22	22	6,4*	25,0
AMPP25	25	6,4*	30,0
AMPP28	28	6,4*	30,0
AMPP30	30	6,4*	30,0
AMPP32	32	6,4*	30,0

Example order- Przykładowe zamówienie:

AMPP 10ax100

How to order see page M.71 - Sposób zamawiania, patrz strona M.71

* Alternative Head Thickness available- Inna grubo główki na życzenie.

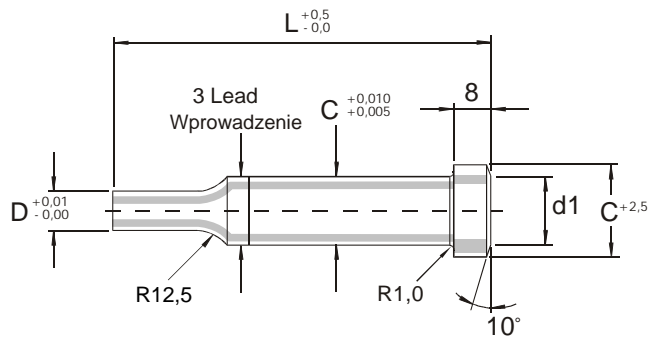

L=Overall standard lengths 50 up to 125mm– L= całkowita standardowa długość 50- 125mm
Any alternative dimensions can be specified– Inne wymiary na życzenie

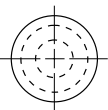

HMT

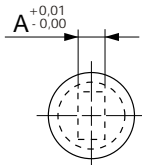

HMR

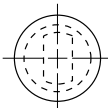

HMF

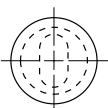

HMW

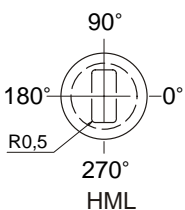

HML

Symbol							
HMT	HMR	HMF	HMW	HML	C	d1	Min. A/D
HMT8	HMR8	HMF8	HMW8	HML8	8	8	2,3
HMT10	HMR10	HMF10	HMW10	HML10	10	10	1,5
HMT12	HMR12	HMF12	HMW12	HML12	12	12	1,5
HMT13	HMR13	HMF13	HMW13	HML13	13	13	1,5
HMT14	HMR14	HMF14	HMW14	HML14	14	14	1,5
HMT16	HMR16	HMF16	HMW16	HML16	16	16	2,3
HMT18	HMR18	HMF18	HMW18	HML18	18	18	3,2
HMT19	HMR19	HMF19	HMW19	HML19	19	19	3,2
HMT20	HMR20	HMF20	HMW20	HML20	20	20	3,2
HMT22	HMR22	HMF22	HMW22	HML22	22	22	4,0
HMT25	HMR25	HMF25	HMW25	HML25	25	25	4,8
HMT28	HMR28	HMF28	HMW28	HML28	28	28	5,0
HMT30	HMR30	HMF30	HMW30	HML30	30	30	5,0
HMT32	HMR32	HMF32	HMW32	HML32	32	32	5,0
HMT35	HMR35	HMF35	HMW35	HML35	35	35	5,0
HMT40	HMR40	HMF40	HMW40	HML40	40	40	5,0
HMT45	HMR45	HMF45	HMW45	HML45	45	45	5,0

Example order- Przykładowe zamówienie:

HMT13D x 10,1x95

HMF20C x 12,4x18x90 SF

How to order see page M.71 - Sposób zamawiania, patrz strona M.71

Location Flats & dowel slots if required (see page M.67,M.68)- Zabezpieczenie przed obrotem i rowki pod kołek (patrz strony M.67,M.68)

Alternative shapes (see page M.64,M.65)- Inne kształty- (patrz strony M.64,M.65)

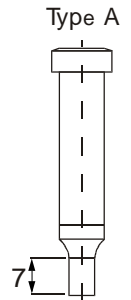

Type B

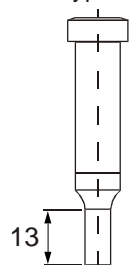

Type C

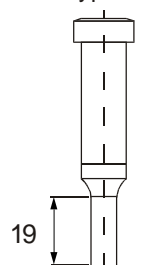

Type D

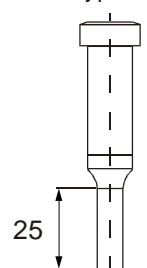

Type AL

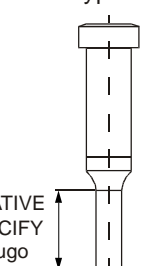

ALTERNATIVE LENGTH SPECIFY
– Inna długość (określić)

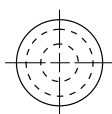
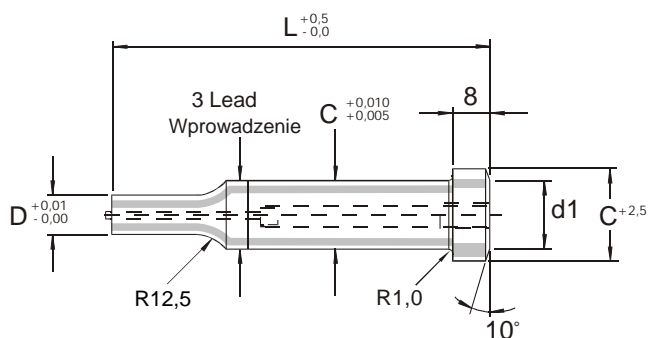

HEMT

L=Overall standard lengths 50 up to 125mm – L= całkowita standardowa długość 50- 125mm
Any alternative dimensions can be specified – Inne wymiary na życzenie

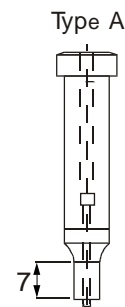

Type B

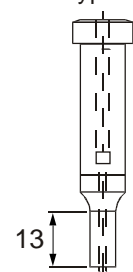

Type C

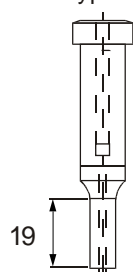

Type D

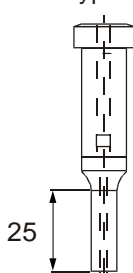

Type AL

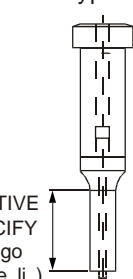

ALTERNATIVE LENGTH SPECIFY – Inna długość (określić)



HEMR

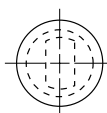

HEMF

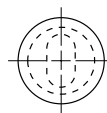

HEMW

Symbol							
HEMT	HEMR	HEMF	HEMW	HEML	C	d1	Min. A/D
HEMT8	HEMR8	HEMF8	HEMW8	HEML8	8	8	2,3
HEMT10	HEMR10	HEMF10	HEMW10	HEML10	10	10	3,2
HEMT12	HEMR12	HEMF12	HEMW12	HEML12	12	12	3,2
HEMT13	HEMR13	HEMF13	HEMW13	HEML13	13	13	3,2
HEMT14	HEMR14	HEMF14	HEMW14	HEML14	14	14	4,0
HEMT16	HEMR16	HEMF16	HEMW16	HEML16	16	16	4,8
HEMT18	HEMR18	HEMF18	HEMW18	HEML18	18	18	5,0
HEMT19	HEMR19	HEMF19	HEMW19	HEML19	19	19	5,0
HEMT20	HEMR20	HEMF20	HEMW20	HEML20	20	20	5,0
HEMT22	HEMR22	HEMF22	HEMW22	HEML22	22	22	5,0
HEMT25	HEMR25	HEMF25	HEMW25	HEML25	25	25	5,0
HEMT28	HEMR28	HEMF28	HEMW28	HEML28	28	28	5,0
HEMT30	HEMR30	HEMF30	HEMW30	HEML30	30	30	5,0
HEMT32	HEMR32	HEMF32	HEMW32	HEML32	32	32	5,0
HEMT35	HEMR35	HEMF35	HEMW35	HEML35	35	35	5,0
HEMT40	HEMR40	HEMF40	HEMW40	HEML40	40	40	5,0
HEMT45	HEMR45	HEMF45	HEMW45	HEML45	45	45	5,0

Example order- Przykładowe zamówienie:

HEMT13D x 10,1x95

HEMF20C x 12,4x18x90 SF

How to order see page M.71 - Sposób zamawiania, patrz strona M.71

Location Flats & dowel slots if required (see page M.67,M.68)- Zabezpieczenie przed obrotem i rowki pod kołek (patrz strony M.67,M.68)

Alternative shapes (see page M.64,M.65)- Inne kształty- (patrz strony M.64,M.65)

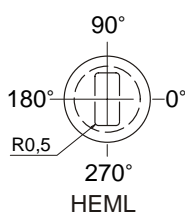

HEML

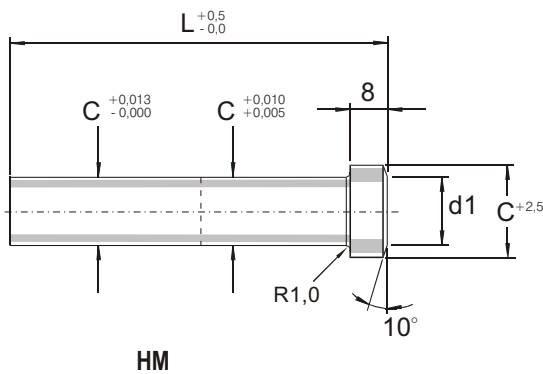

HM

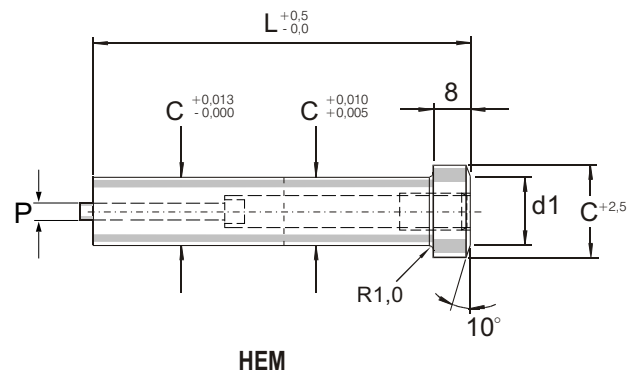

HEM

L=Overall standard lengths 50 up to 125mm– L= całkowita standardowa długość 50- 125mm
Any alternative dimensions can be specified– Inne wymiary na życzenie

Solid
Stempel zwykłe

Symbol	C	d1
HM8	8	8
HM10	10	10
HM12	12	12
HM13	13	13
HM14	14	14
HM16	16	16
HM18	18	18
HM19	19	19
HM20	20	20
HM22	22	22
HM25	25	25
HM28	28	28
HM30	30	30
HM32	32	32
HM35	35	35
HM40	40	40
HM45	45	45

Ejector
Stempel z wyrzutnikiem

Symbol	C/d1	P
HEM8	8	1
HEM10	10	1,5
HEM12	12	1,5
HEM13	13	1,5
HEM14	14	1,5
HEM16	16	2,4
HEM18	18	2,4
HEM19	19	2,4
HEM20	20	2,4
HEM22	22	2,4
HEM25	25	2,4
HEM28	28	2,4
HEM30	30	2,4
HEM32	32	2,4
HEM35	35	2,4
HEM40	40	2,4
HEM45	45	2,4

Example order- Przykładowe zamówienie:

HM13 x 95

HEM10 x 80

How to order see page M.70 - Sposób zamawiania, patrz strona M.70

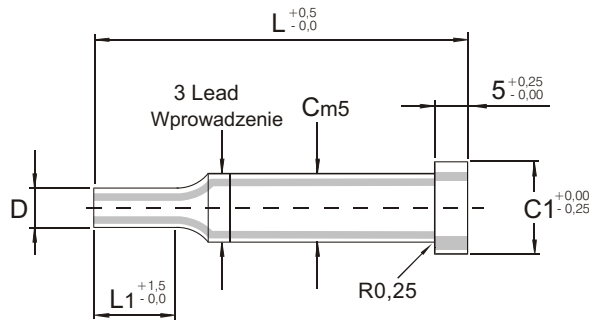

Material- Materiał 1.3343 (M2)
Heads-Główna 52+5HRC
Shank-Trzon 64±2 HRC

Symbol					Min.			L								L1	L1
PT	PR	PW	PF	PL	C	C1	A/D	50	56	60	63	71	80	90	100	std	Alt
PT4	PR4	PW4	PF4	PL4	4	7	2,3	*	*	*	*	*	*	*	*	16	S P E C I F Y
PT5	PR5	PW5	PF5	PL5	5	8	2,3	*	*	*	*	*	*	*	*	16	
PT6	PR6	PW6	PF6	PL6	6	9	2,3	*	*	*	*	*	*	*	*	16	
PT8	PR8	PW8	PF8	PL8	8	11	3,0	*	*	*	*	*	*	*	*	20	
PT10	PR10	PW10	PF10	PL10	10	13	4,8	*	*	*	*	*	*	*	*	20	
PT13	PR13	PW13	PF13	PL13	13	16	4,8	*	*	*	*	*	*	*	*	25	
PT16	PR16	PW16	PF16	PL16	16	19	5,5	*	*	*	*	*	*	*	*	25	
PT20	PR20	PW20	PF20	PL20	20	23	5,5	*	*	*	*	*	*	*	*	25	
PT25	PR25	PW25	PF25	PL25	25	28	5,5	*	*	*	*	*	*	*	*	25	
PT32	PR32	PW32	PF32	PL32	32	35	5,5	*	*	*	*	*	*	*	*	32	

Location Flats if required (see page M.66, M.67)- Zabezpieczenie przed obrotem na życzenie (patrz strony M.66, M.67)

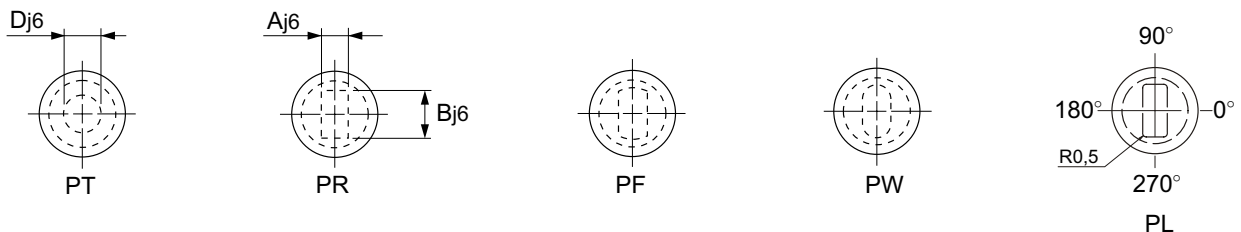

Example order- Przykładowe zamówienie:

PT5x 3,0871

PW16x12x8x80 L1=25

How to order see page M.70 - Sposób zamawiania, patrz strona M.70

Non standard form lengths should be specified as eg:- Niestandardową długość końcówki tnącej proszę określić tak, jak w przykładzie: eg: PW16(25)*12x8x80

Alternative shapes available (see page M.63, M.64)- Inne kształty- (patrz strony M.63, M.64)

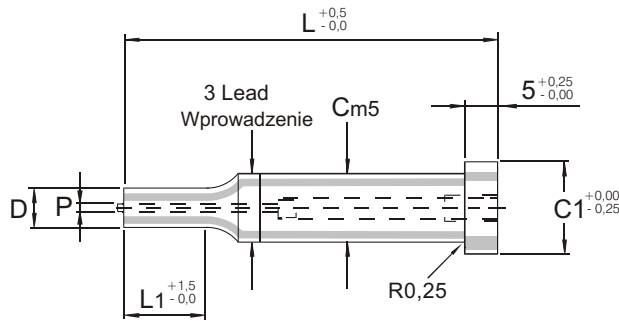

Material- Materiał 1.3343 (M2)
Heads-Główna 52+5HRC
Shank-Trzon 64±2 HRC

Symbol					Min.				L								L1	L1
PET	PER	PEW	PEF	PEL	C	C1	P	A/D	50	56	60	63	71	80	90	100	std	Alt
PET5	PER5	PEW5	PEF5	PEL5	5	8	1,0	2,5	*	*	*	*	*	*	*	*	16	SPECYFICZNY OKREŚLIĆ
PET6	PER6	PEW6	PEF6	PEL6	6	9	1,0	2,5	*	*	*	*	*	*	*	*	16	
PET8	PER8	PEW8	PEF8	PEL8	8	11	1,0	3,0	*	*	*	*	*	*	*	*	20	
PET10	PER10	PEW10	PEF10	PEL10	10	13	1,5	4,8	*	*	*	*	*	*	*	*	20	
PET13	PER13	PEW13	PEF13	PEL13	13	16	1,5	4,8	*	*	*	*	*	*	*	*	25	
PET16	PER16	PEW16	PEF16	PEL16	16	19	2,4	5,5	*	*	*	*	*	*	*	*	25	
PET20	PER20	PEW20	PEF20	PEL20	20	23	2,4	5,5	*	*	*	*	*	*	*	*	25	
PET25	PER25	PEW25	PEF25	PEL25	25	28	2,4	5,5	*	*	*	*	*	*	*	*	25	
PET32	PER32	PEW32	PEF32	PEL32	32	35	2,4	5,5	*	*	*	*	*	*	*	*	32	

Location Flats if required (see page M.66, M.67)- Zabezpieczenie przed obrotem na życzenie (patrz strony M.66, M.67)

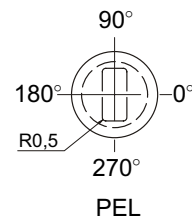
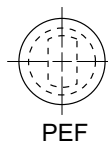
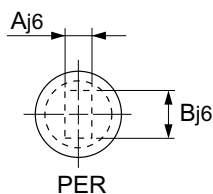
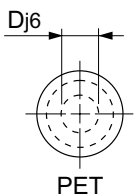

Example order- Przykładowe zamówienie:

PET5x 3,0871

PEW16x12x8x80 L1=25

How to order see page M.70 - Sposób zamawiania, patrz strona M.70

Non standard form lengths should be specified as eg:- Niestandardową długość końcówki tnącej proszę określić tak, jak w przykładzie: eg: PW16(25)*12x8x80

Alternative shapes available (see page M.63, M.64)- Inne kształty- (patrz strony M.63, M.64)

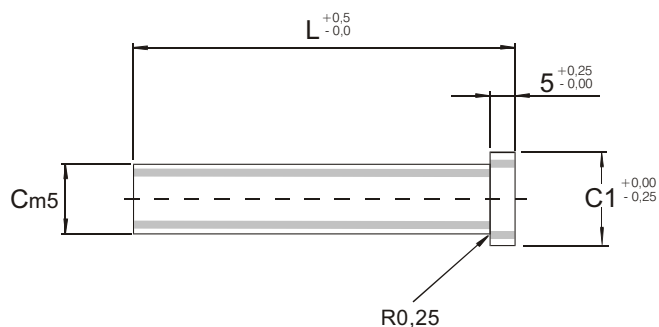

Material- Materiał 1.3343 (M2)
Heads-Główna 52+5HRC
Shank-Trzon 64±2 HRC

SYMBOL	C	C1	L									
			50	56	60	63	71	80	90	100	125	
PB4	4	7	*	*	*	*	*	*	*	*	*	
PB5	5	8	*	*	*	*	*	*	*	*	*	
PB6	6	9	*	*	*	*	*	*	*	*	*	
PB8	8	11	*	*	*	*	*	*	*	*	*	
PB10	10	13	*	*	*	*	*	*	*	*	*	
PB13	13	16	*	*	*	*	*	*	*	*	*	
PB16	16	19	*	*	*	*	*	*	*	*	*	
PB20	20	23	*	*	*	*	*	*	*	*	*	
PB25	25	28	*	*	*	*	*	*	*	*	*	
PB32	32	35	*	*	*	*	*	*	*	*	*	

Example order- Przykładowe zamówienie:

PB5x71

Pb16x80

How to order see page M.70 - Sposób zamawiania, patrz strona M.70

Alternative sizes on request - Inne wymiary na życzenie

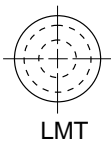
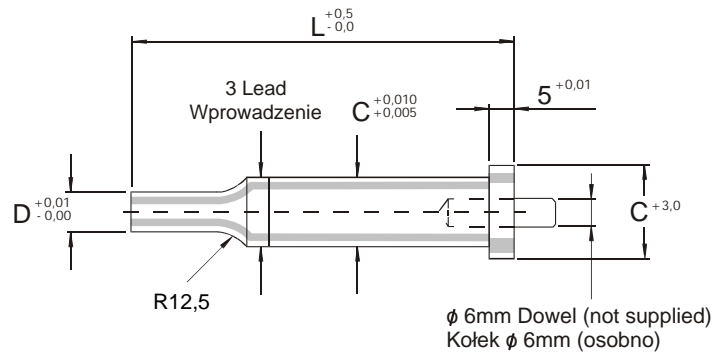

L=Overall standard lengths 50 up to 125mm – L= całkowita standardowa długość 50- 125mm
Any alternative dimensions can be specified – Inne wymiary na życzenie

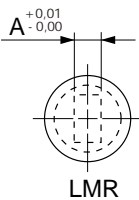

Symbol						
LMT	LMR	LMF	LMW	LML	C	Min. D
LMT10	LMR10	LMF10	LMW10	LML10	10	3,2
LMT13	LMR13	LMF13	LMW13	LML13	13	3,2
LMT16	LMR16	LMF16	LMW16	LML16	16	4,8
LMT20	LMR20	LMF20	LMW20	LML20	20	5,0
LMT25	LMR25	LMF25	LMW25	LML25	25	5,0
LMT32	LMR32	LMF32	LMW32	LML32	32	5,0

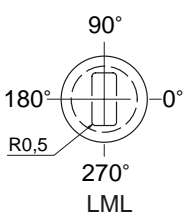
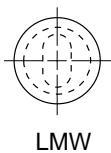

Example order- Przykładowe zamówienie:

LMR32D x 20x14,6x80

How to order see page M.71 - Sposób zamawiania, patrz strona M.71

Location Flats if required (see page M..67,M.68)- Zabezpieczenie przed obrotem (patrz strony M.67,M.68)

Alternative shapes (see page M.64,M.65)- Inne kształty- (patrz strony M.64,M.65)

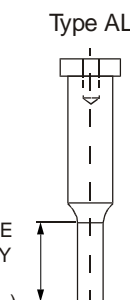
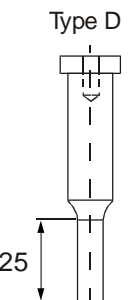
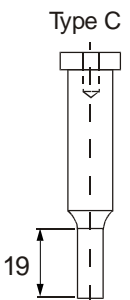
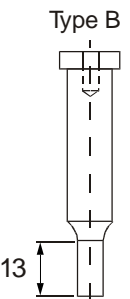
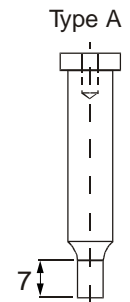

ALTERNATIVE LENGTH SPECIFY
– Inna długość
(określić)

ISO 8020

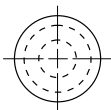
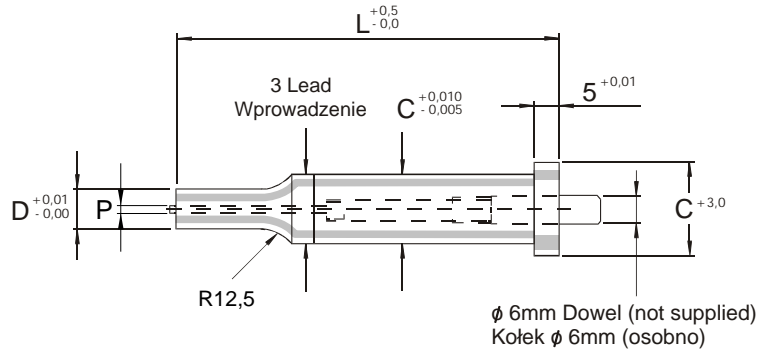

LMET

L=Overall standard lengths 50 up to 125mm— L= całkowita standardowa długość 50- 125mm
Any alternative dimensions can be specified— Inne wymiary na życzenie

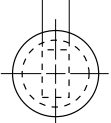

LMER

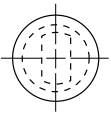

LMEF

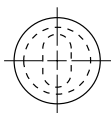

LMEW

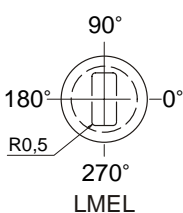

LMEL

Symbol							Min.
LMET	LMER	LMEF	LMEW	LMEL	C	P	A/D
LMET10	LMER10	LMEF10	LMEW10	LMEL10	10	1,5	4,8
LMET13	LMER13	LMEF13	LMEW13	LMEL13	13	1,5	4,8
LMET16	LMER16	LMEF16	LMEW16	LMEL16	16	2,4	5,5
LMET20	LMER20	LMEF20	LMEW20	LMEL20	20	2,4	5,5
LMET25	LMER25	LMEF25	LMEW25	LMEL25	25	2,4	5,5
LMET32	LMER32	LMEF32	LMEW32	LMEL32	32	2,4	5,5

Example order- Przykładowe zamówienie:

LMER32D x 20x14,6x80

How to order see page M.71 - Sposób zamawiania, patrz strona M.71

Location Flats if required (see page M.67,M.68)- Zabezpieczenie przed obrotem (patrz strony M.67,M.68)

Alternative shapes (see page M.64,M.65)- Inne kształty- (patrz strony M.64,M.65)

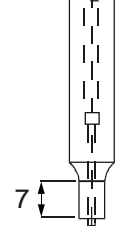
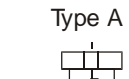

Type B

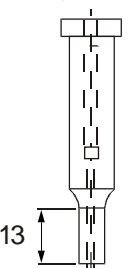

Type C

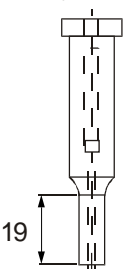

Type D

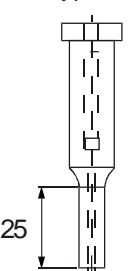

Type AL

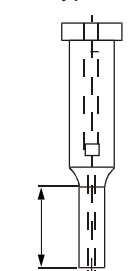

ALTERNATIVE
LENGTH SPECIFY
– Inna długość
(określić)

ISO 8020

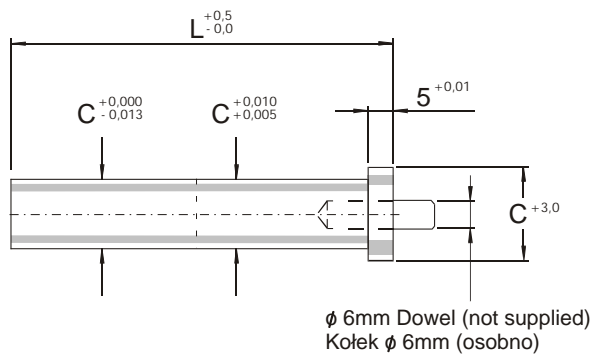

Any alternative dimensions can be specified– Inne wymiary na życzenie

Symbol	C	L						
		56	63	71	80	90	100	125
LM10	10	*	*	*	*	*	*	*
LM13	13	*	*	*	*	*	*	*
LM16	16	*	*	*	*	*	*	*
LM20	20	*	*	*	*	*	*	*
LM25	25	*	*	*	*	*	*	*
LM32	32	*	*	*	*	*	*	*

Example order- Przykładowe zamówienie:

Lm10x80

How to order see page M.71 - Sposób zamawiania, patrz strona M.71

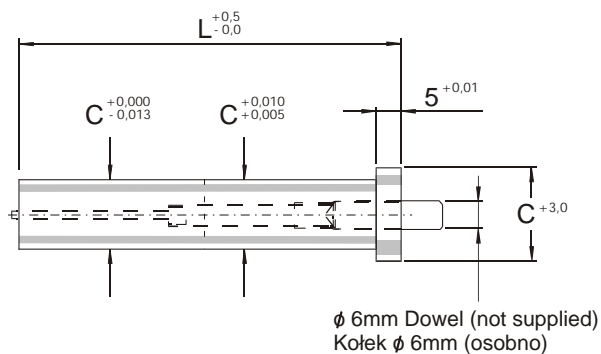

Any alternative dimensions can be specified– Inne wymiary na życzenie

Symbol	C	L						
		56	63	71	80	90	100	125
LME10	10	*	*	*	*	*	*	*
LME13	13	*	*	*	*	*	*	*
LME16	16	*	*	*	*	*	*	*
LME20	20	*	*	*	*	*	*	*
LME25	25	*	*	*	*	*	*	*
LME32	32	*	*	*	*	*	*	*

Example order- Przykładowe zamówienie:

LME10x80

How to order see page M.71 - Sposób zamawiania, patrz strona M.71

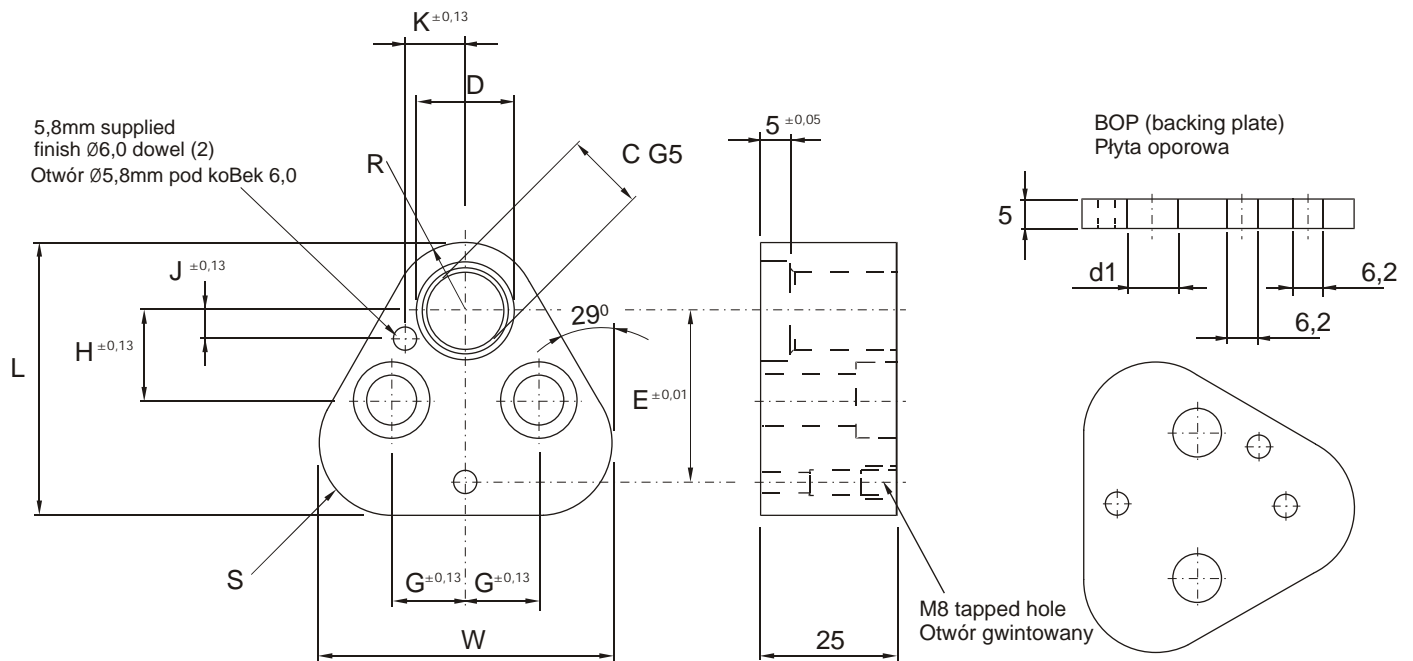

Symbol	C	L	W	D	G	H	R	S	E	K	J	Screw size Gwint
HHR10	10 ^{+0,009} _{.0}	44,5	43,7	14,0	11,12	19,0	9,5	12,0	26,925	9,0	7,5	M8
HHR13	13 ^{+0,011} _{.0}	50,8	50,0	17,0	14,27	19,0	12,7	15,2	29,970	12,0	6,5	M8
HHR16	16 ^{+0,011} _{.0}	54,0	53,2	20,0	15,87	19,0	14,3	16,8	31,750	13,5	6,0	M8
HHR20	20 ^{+0,013} _{.0}	60,3	59,6	24,0	17,47	19,0	17,5	20,0	33,530	16,5	5,0	M10
HHR25	25 ^{+0,013} _{.0}	69,9	69,1	29,0	19,84	23,8	22,2	24,7	40,640	22,0	7,0	M12
HHR32	32 ^{+0,016} _{.0}	69,9	69,1	36,0	19,84	23,8	22,2	24,7	40,640	22,0	7,0	M12

Backing Plate	
Płyta oporowa	d1
BOP10	10
BOP13	10
BOP16	10
BOP20	12
BOP25	14
BOP32	14

5mm punch head only
Tylko dla stempli z główkami o grubo ci 5mm

Example order- Przykładowe zamówienie:
HHR13
BOP13

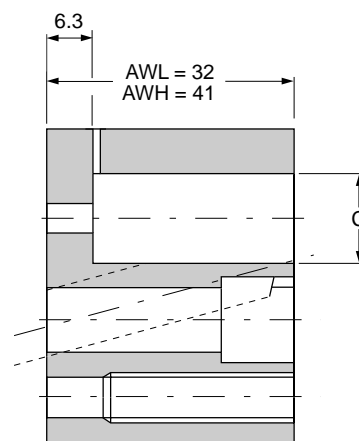
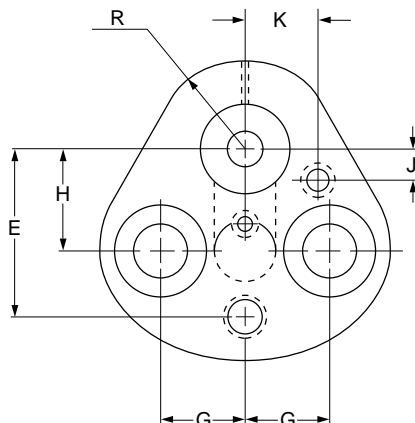

Light duty - do niskich obciążeń

Symbol	Shank Dia. średnica trzonu stempla C	E	G	R	H	J	K	Screw size Gwint
AWL-06	06	23,000	11,10	8,0	19,00	9,00	8,00	M6
AWL-10	10	26,924	11,12	9,5	19,05	7,50	9,00	M8
AWL-13	13	29,972	14,27	12,7	19,05	6,50	12,00	M8
AWL-16	16	31,750	15,87	14,3	19,05	6,00	13,50	M8
AWL-20	20	33,528	17,47	17,5	19,05	5,00	16,50	M8
AWL-25	25	40,640	19,84	22,2	23,82	7,00	22,00	M12
AWL-32	32	40,640	19,84	22,2	23,82	7,00	22,00	M12
*AWL-38	38	43,993	24,00	26,0	27,00	10,00	26,00	M12

Heavy duty - do wysokich obciążeń

Symbol	Shank Dia. średnica trzonu stempla C	E	G	R	H	J	K	Screw size Gwint
AWH-10	10	26,924	11,12	9,5	19,05	7,50	9,00	M8
AWH-13	13	29,972	14,27	12,7	19,05	6,50	12,00	M8
AWH-16	16	31,750	15,87	14,3	19,05	6,00	13,50	M8
AWH-20	20	33,528	17,47	17,5	19,05	5,00	16,50	M8
AWH-25	25	40,640	19,84	22,2	23,82	7,00	22,00	M12
AWH-32	32	40,640	19,84	22,2	23,82	7,00	22,00	M12
AWH-40	40	43,993	24,00	26,0	27,00	10,00	26,00	M12

Example order- Przykładowe zamówienie:

AWH-13

*AWL-38 is manufactured as a special - AWL-38 jest traktowany jako wyrób specjalny

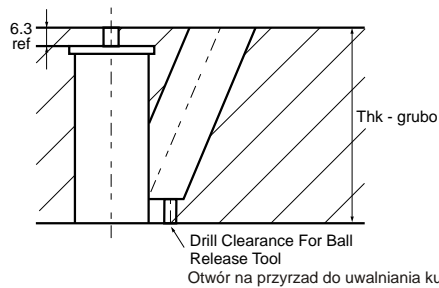
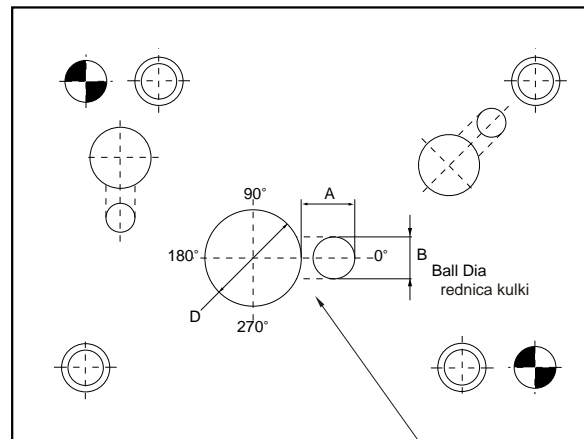

Specify radial location in degrees anti clockwise from 0°
Prosz okre li pozycj radialn w stopniach zaczynaj c 0 w kierunku przeciwnym do ruchu wskazówek zegara

Light duty - do niskich obci e

Symbol	D	A	B	Thk grubo
AWML6	6	12	6	32
AWML10	10	13	8	32
AWML13	13	13	8	32
AWML16	16	13	8	32
AWML20	20	13	8	32
AWML25	25	13	8	32
AWML32	32	13	8	32
AWML38	38	13	8	32

Heavy duty - do wysokich obci e

Symbol	D	A	B	Thk grubo
AWMH10	10	15	10	41
AWMH13	13	17	12	41
AWMH16	16	17	12	41
AWMH20	20	17	12	41
AWMH25	25	17	12	41
AWMH32	32	17	12	41
AWMH40	40	17	12	41

Punch Shape Kształt stempla	Class Ball Hole Klasa otworu na kulk	Radial Tolerance Tolerancja radialna
Round Okr gły	R	$\pm 5^0$
Shaped Kształtowy	F	$\pm 0^05'$

Standard Tolerances – Standardowe tolerancje	
Outside edges Kraw dzie zewn trzne	$\pm 0,5\text{mm}$
Dowel Hole Locations Pozycje otworów na kołek ustalaj cy	$\pm 0,01\text{mm}$
Screw Hole Locations Pozycje otworów na ruby	$\pm 0,01\text{mm}$
Component Hole Locations Pozycje otworów na komponenty	$\pm 0,01\text{mm}$

Class R Supplied unless otherwise Specified
Robione w klasie R o ile nie okre lono inaczej
Example order- Przykładowe zamówienie:
AWML10 F



BACKING
PLATE
PŁYTKA
OPOROWA

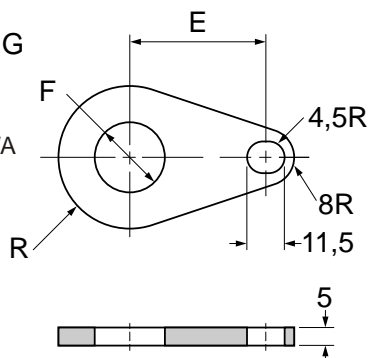

RETAINING – PŁYTKA PODTRZYMUJ CA
PLATE

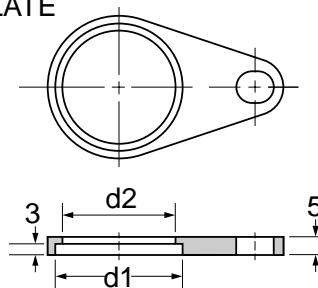

Retainer & Backing Plate Set Zestaw: płytka oporowa i podtrzymuj ca	F	d2	d1	R	E
AWR-10	10	19	22	13,0	28,0
AWR-13	13	24	27	15,5	31,0
AWR-16	16	29	32	18,0	32,9
AWR-20	20	34	37	20,5	34,8
AWR-25	25	41	44	24,0	39,8
AWR-32	32	51	57	31,0	41,3
AWR-40	40	61	66	36,0	45,0

Set consists of: Backing plate, Reaining plate and M8x20 socked head cap screw.

Zestaw składa si z: płytki wspieraj cej, płytki przytrzymuj cej i ruby z łbem walcowym M8x20



Stripper Catalog Number Nr. Katalog. tulei	Punch Shank Trzon Stempla	D3	d4	L	d3	D2	b
AWS10-43	10	9,75	18	43	21	1,6	6
AWS10-52	10	9,75	18	52	21	1,6	6
AWS10-63	10	9,75	18	63	21	1,6	6
AWS10-72	10	9,75	18	72	21	1,6	6
AWS13-43	13	12,75	23	43	26	3,0	6
AWS13-52	13	12,75	23	52	26	3,0	6
AWS13-63	13	12,75	23	63	26	3,0	6
AWS13-72	13	12,75	23	72	26	3,0	6
AWS16-43	16	15,75	28	43	31	3,0	6
AWS16-52	16	15,75	28	52	31	3,0	6
AWS16-63	16	15,75	28	63	31	3,0	6
AWS16-72	16	15,75	28	72	31	3,0	6
AWS20-43	20	19,75	33	43	36	3,0	7
AWS20-52	20	19,75	33	52	36	3,0	7
AWS20-63	20	19,75	33	63	36	3,0	7
AWS20-72	20	19,75	33	72	36	3,0	7
AWS25-43	25	24,75	40	43	43	3,0	7
AWS25-52	25	24,75	40	52	43	3,0	7
AWS25-63	25	24,75	40	63	43	3,0	7
AWS25-72	25	24,75	40	72	43	3,0	7
AWS32-43	32	31,70	50	43	55	3,0	7
AWS32-52	32	31,70	50	52	55	3,0	7
AWS32-63	32	31,70	50	63	55	3,0	7
AWS32-72	32	31,70	50	72	55	3,0	7
AWS40-43	40	39,70	60	43	65	3,0	8
AWS40-63	40	39,70	60	63	65	3,0	8

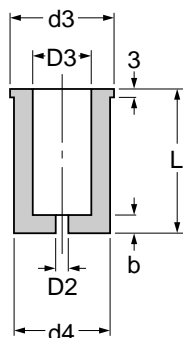

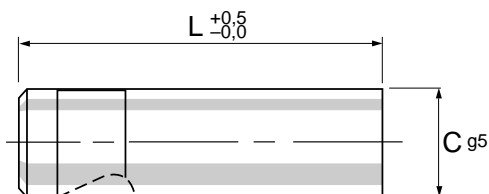

LAW HAW

Solid
Stemple zwykłe

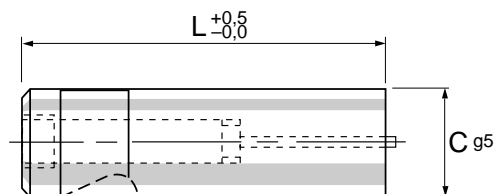

LEW HEW

Ejector
Stemple z wyrzutnikiem

L= 56 63 71 80 90 100 125

Light Duty do niskich obci e	C	Heavy Duty do wysokich obci e	C
LAW	6		
LAW	10	HAW	10
LAW	13	HAW	13
LAW	16	HAW	16
LAW	20	HAW	20
LAW	25	HAW	25
LAW	32	HAW	32
LAW	38		
		HAW	40

L= 56 63 71 80 90 100 125

Light Duty do niskich obci e	C	Heavy Duty do wysokich obci e	C
LEW	6		
LEW	10	HEW	10
LEW	13	HEW	13
LEW	16	HEW	16
LEW	20	HEW	20
LEW	25	HEW	25
LEW	32	HEW	32
LEW	38		
		HEW	40

Example order- Przykładowe zamówienie:

LAW16 x 80

HEW16 x 80

How to order see page M.71 - Sposób zamawiania, patrz strona M.71

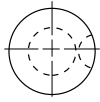
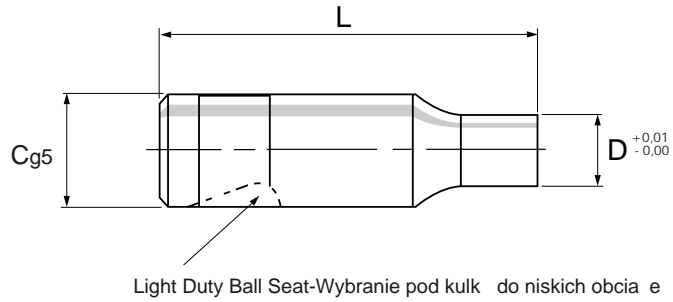

LBT

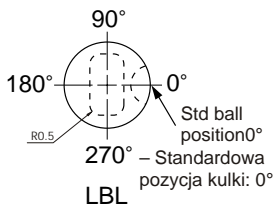
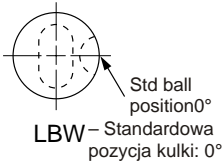
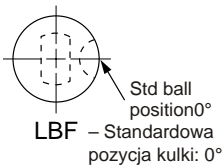
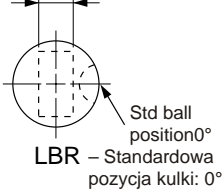
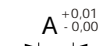

Overall standard lengths 50 up to 125mm
Całkowita standardowa długość 50- 125mm

Symbol					Min.	Min.	
LBT	LBR	LBF	LBW	LBL	C	D	A
LBT6	LBR6	LBF6	LBW6	LBL6	6	2,5	2,5
LBT10	LBR10	LBF10	LBW10	LBL10	10	3,2	3,2
LBT13	LBR13	LBF13	LBW13	LBL13	13	3,2	3,2
LBT16	LBR16	LBF16	LBW16	LBL16	16	4,8	4,8
LBT20	LBR20	LBF20	LBW20	LBL20	20	5,0	5,0
LBT25	LBR25	LBF25	LBW25	LBL25	25	5,0	5,0
LBT32	LBR32	LBF32	LBW32	LBL32	32	5,0	6,0
LBT38	LBR38	LBF38	LBW38	LBL38	38	8,0	6,0

Example order- Przykładowe zamówienie:

LBF13Bx 4 x 9 x 60

How to order see page M.71 - Sposób zamawiania, patrz strona M.71

Specify Ball Seat Positions- Prosz określić pozycję dla wybrania pod kulki

Alternative shapes available (see page M.64,M.65)- Inne kształty- (patrz strony M.64,M.65)

Type A

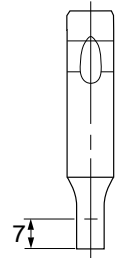

Type B

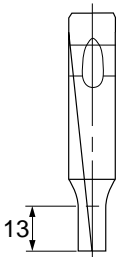

Type C

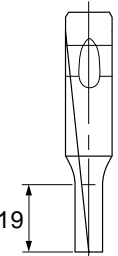

Type D

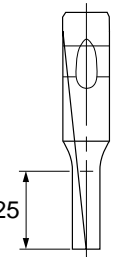

Type AL

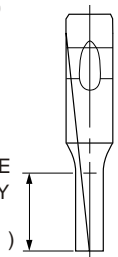

ALTERNATIVE LENGTH SPECIFY
– Inna długość
(określi)

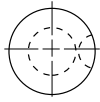
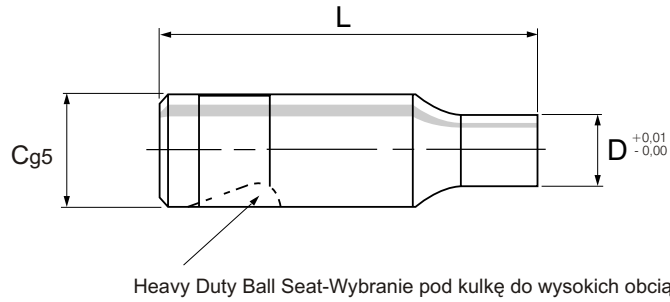

HBT

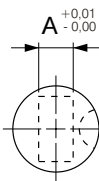

HBR – Standardowa pozycja kulki: 0°



HBF – Standardowa pozycja kulki: 0°



HBW – Standardowa pozycja kulki: 0°

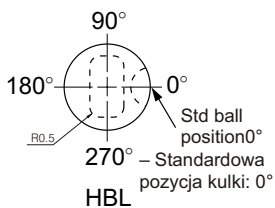

HBL

Overall standard lengths 50 up to 125mm
Całkowita standardowa długość 50- 125mm

Symbol					Min.	Min.	
HBT	HBR	HBF	HBW	HBL	C	D	A
HBT10	HBR10	HBF10	HBW10	HBL10	10	3,2	3,2
HBT13	HBR13	HBF13	HBW13	HBL13	13	3,2	3,2
HBT16	HBR16	HBF16	HBW16	HBL16	16	4,8	4,8
HBT20	HBR20	HBF20	HBW20	HBL20	20	5,0	5,0
HBT25	HBR25	HBF25	HBW25	HBL25	25	5,0	5,0
HBT32	HBR32	HBF32	HBW32	HBL32	32	5,0	6,0
HBT40	HBR40	HBF40	HBW40	HBL40	40	8,0	8,0

Example order- Przykładowe zamówienie:

HBF13Bx 4 x 9 x 60

How to order see page M.70 - Sposób zamawiania, patrz strona M.70

Specify Ball Seat Positions- Proszę określić pozycję dla wybrania pod kulkę

Alternative shapes available (see page M.63, M.64)- Inne kształty- (patrz strony M.63, M.64)

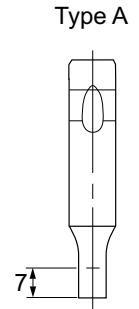

Type A

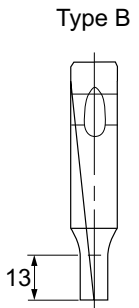

Type B

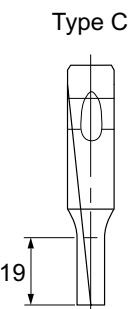

Type C

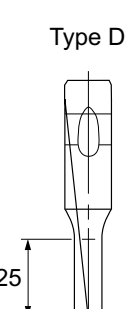

Type D

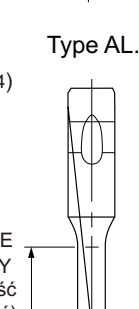

Type AL

ALTERNATIVE LENGTH SPECIFY
- Inna długość (określić)

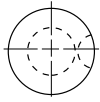
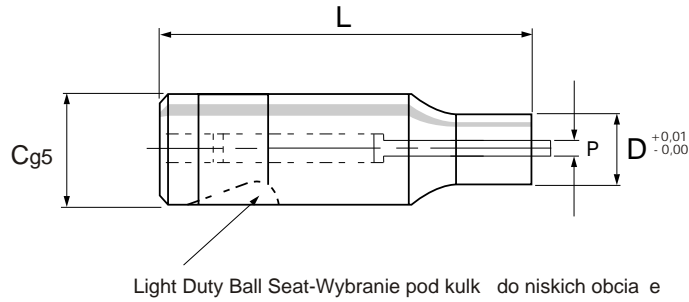

LEBT

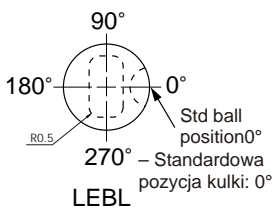
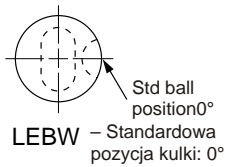
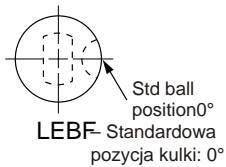
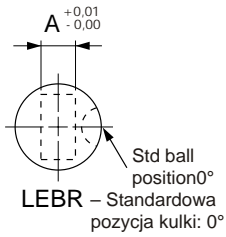

Overall standard lengths 50 up to 125mm
Całkowita standardowa długość 50- 125mm

Symbol					Min.	Min.		
LEBT	LEBR	LEBF	LEBW	LEBL	C	D	A	P
LEBT10	LEBR10	LEBF10	LEBW10	LEBL10	10	3,2	3,2	1,5
LEBT13	LEBR13	LEBF13	LEBW13	LEBL13	13	3,2	3,2	1,5
LEBT16	LEBR16	LEBF16	LEBW16	LEBL16	16	4,8	4,8	2,4
LEBT20	LEBR20	LEBF20	LEBW20	LEBL20	20	5,0	5,0	2,4
LEBT25	LEBR25	LEBF25	LEBW25	LEBL25	25	5,0	5,0	2,4
LEBT32	LEBR32	LEBF32	LEBW32	LEBL32	32	5,0	6,0	2,4
LEBT38	LEBR38	LEBF38	LEBW38	LEBL38	38	8,0	6,0	2,4

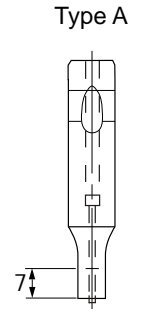

Type B

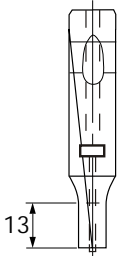

Type C

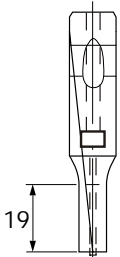

Type D

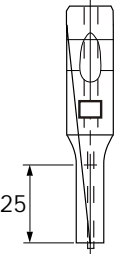

Type AL

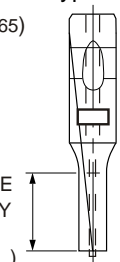

ALTERNATIVE LENGTH SPECIFY
– Inna długość
(określi)

Example order- Przykładowe zamówienie:

LEBF13Bx 4 x 9 x 60

How to order see page M.71 - Sposób zamawiania, patrz strona M.71

Specify Ball Seat Positions- Prosz określić pozycję dla wybrania pod kulki

Alternative shapes available (see page M.64,M.65)- Inne kształty- (patrz strony M.64,M.65)

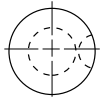
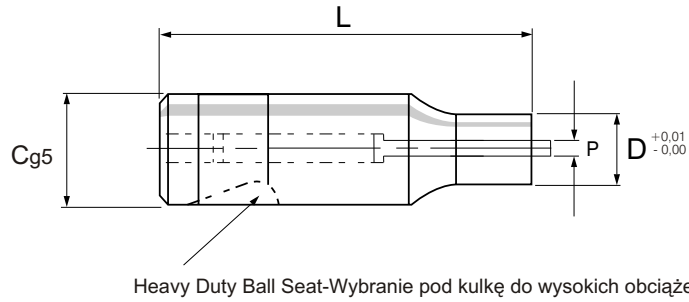

HEBT

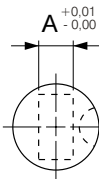

HEBR – Standardowa pozycja kulki: 0°



HEBF – Standardowa pozycja kulki: 0°

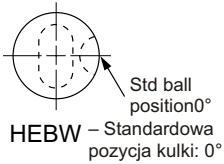

HEBW – Standardowa pozycja kulki: 0°

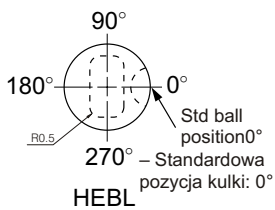

HEBL

Overall standard lengths 50 up to 125mm
Całkowita standardowa długość 50- 125mm

Symbol					Min.	Min.		
HEBT	HEBR	HEBF	HEBW	HEBL	C	D	A	P
HEBT10	HEBR10	HEBF10	HEBW10	HEBL10	10	3,2	3,2	1,5
HEBT13	HEBR13	HEBF13	HEBW13	HEBL13	13	3,2	3,2	1,5
HEBT16	HEBR16	HEBF16	HEBW16	HEBL16	16	4,8	4,8	2,4
HEBT20	HEBR20	HEBF20	HEBW20	HEBL20	20	5,0	5,0	2,4
HEBT25	HEBR25	HEBF25	HEBW25	HEBL25	25	5,0	5,0	2,4
HEBT32	HEBR32	HEBF32	HEBW32	HEBL32	32	5,0	6,0	2,4
HEBT40	HEBR40	HEBF40	HEBW40	HEBL40	40	8,0	8,0	2,4

Example order- Przykładowe zamówienie:

HEBF13Bx 4 x 9 x 60

How to order see page M.70 - Sposób zamawiania, patrz strona M.70

Specify Ball Seat Positions- Proszę określić pozycję dla wybrania pod kulkę

Alternative shapes available (see page M.63, M.64)- Inne kształty- (patrz strony M.63, M.64)

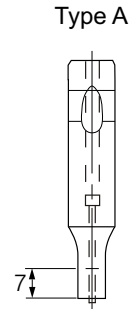

Type B

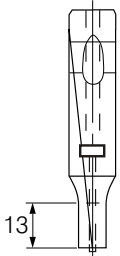

Type C

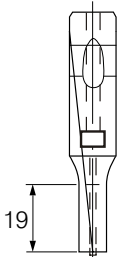

Type D

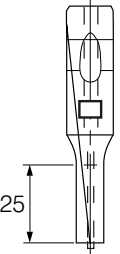

Type AL

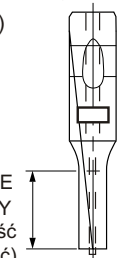

ALTERNATIVE LENGTH SPECIFY
– Inna długość (określić)



Solid type
Stempel zwykły

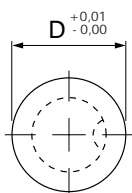

ALT

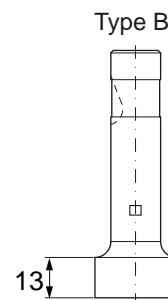
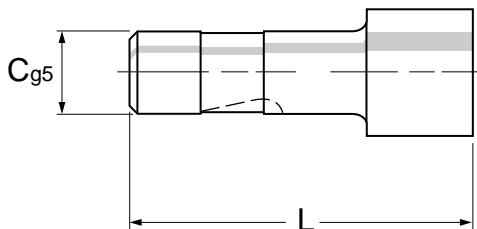

Overall standard lengths 56 up to 125mm
Całkowita standardowa długość 56- 125mm

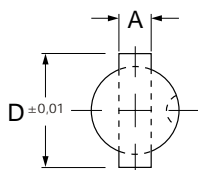

ALR

Symbol						Min.	Max.
ALT	ALR	ALF	ALW	ALL	C	A	D
ALT10	ALR10	ALF10	ALW10	ALL10	10	5,0 - 24,0	
ALT13	ALR13	ALF13	ALW13	ALL13	13	5,0 - 32,0	
ALT16	ALR16	ALF16	ALW16	ALL16	16	6,0 - 38,0	
ALT20	ALR20	ALF20	ALW20	ALL20	20	8,0 - 38,0	
ALT25	ALR25	ALF25	ALW25	ALL25	25	10,0 - 45,0	
ALT32	ALR32	ALF32	ALW32	ALL32	32	12,0 - 45,0	
ALT38	ALR38	ALF38	ALW38	ALL38	38	15,0 - 50,0	

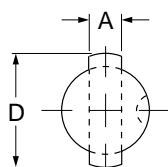
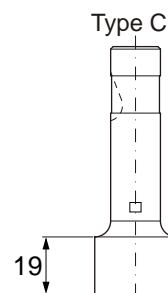

ALF

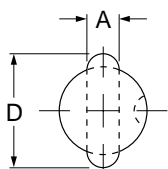

AELW

Example order- Przykładowe zamówienie:

ALL20C 8,6 x 21,30 x 90

How to order see page M.71 - Sposób zamawiania, patrz strona M.71

Specify Ball Seat Positions- Prosz okre li pozycj dla wybrania pod kulk

Alternative shapes available (see page M.64,M.65)- Inne kształty- (patrz strony M.64,M.65)

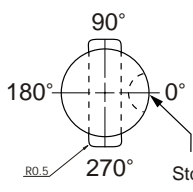
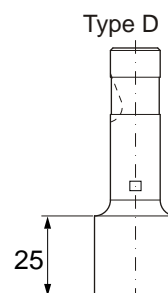

ALL

Std ball position 0°
Standardowa pozycja kulki: 0°

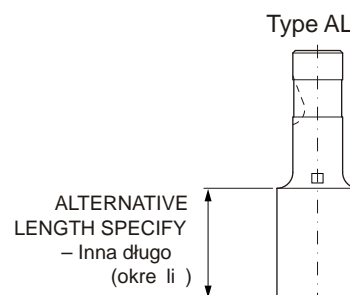



Solid type
Stempel zwykły

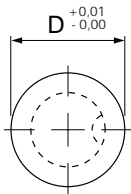

AHT

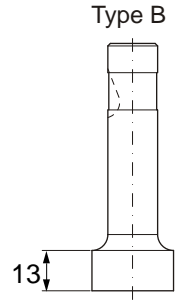
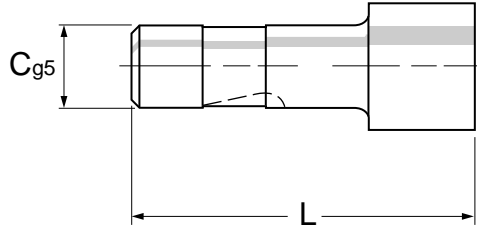

Overall standard lengths 56 up to 125mm
Całkowita standardowa długość 56- 125mm

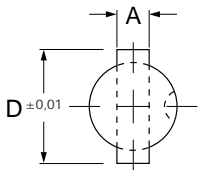

AHR

Symbol						Min.	Max.
AHT	AHR	AHF	AHW	AHL	C	A	D
AHT10	AHR10	AHF10	AHW10	AHL10	10	5,0 - 24,0	
AHT13	AHR13	AHF13	AHW13	AHL13	13	5,0 - 32,0	
AHT16	AHR16	AHF16	AHW16	AHL16	16	6,0 - 38,0	
AHT20	AHR20	AHF20	AHW20	AHL20	20	8,0 - 38,0	
AHT25	AHR25	AHF25	AHW25	AHL25	25	10,0 - 45,0	
AHT32	AHR32	AHF32	AHW32	AHL32	32	12,0 - 45,0	
AHT40	AHR40	AHF40	AHW40	AHL40	40	15,0 - 50,0	

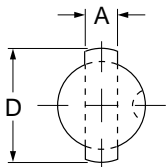
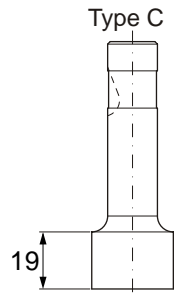

AHF

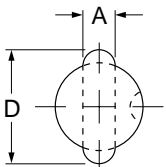
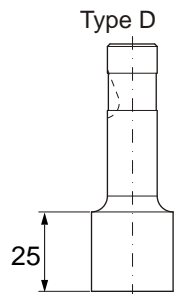

AHW

Example order- Przykładowe zamówienie:

AHR16C 8,4 x 21,60 x 80

How to order see page M.71 - Sposób zamawiania, patrz strona M.71

Specify Ball Seat Positions- Prosz okre li pozycj dla wybrania pod kulk

Alternative shapes available (see page M.64,M.65)- Inne kształty- (patrz strony M.64,M.65)

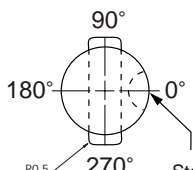

AHL

Std ball position 0°
Standardowa pozycja kulki: 0°

Type AL

ALTERNATIVE LENGTH SPECIFY
- Inna długość (okre li)

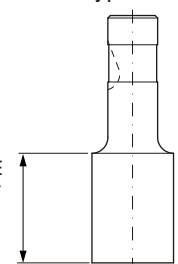



Ejector type
Stempel z wyrzutnikiem

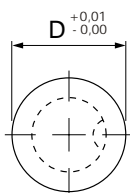

AELT

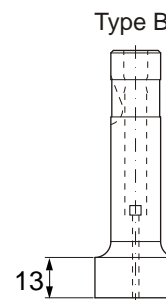
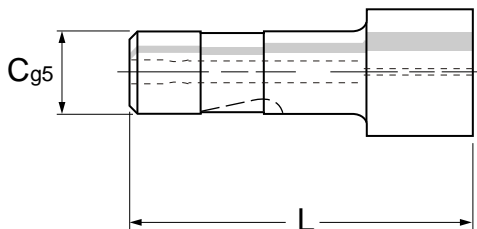

Overall standard lengths 56 up to 125mm
Całkowita standardowa długość 56- 125mm

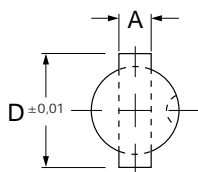

AELR

Symbol						Min.	Max.
AELT	AELR	AELF	AELW	AELL	C	A	D
AELT10	AELR10	AELF10	AELW10	AELL10	10	10,0 - 24,0	
AELT13	AELR13	AELF13	AELW13	AELL13	13	10,0 - 32,0	
AELT16	AELR16	AELF16	AELW16	AELL16	16	10,0 - 38,0	
AELT20	AELR20	AELF20	AELW20	AELL20	20	10,0 - 38,0	
AELT25	AELR25	AELF25	AELW25	AELL25	25	15,0 - 45,0	
AELT32	AELR32	AELF32	AELW32	AELL32	32	15,0 - 45,0	
AELT38	AELR38	AELF38	AELW38	AELL38	38	15,0 - 50,0	

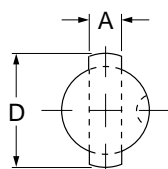
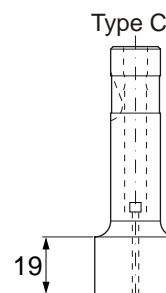

AELF

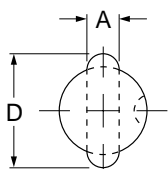
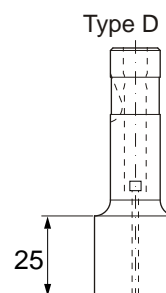

AELW

Example order- Przykładowe zamówienie:

AELR16C 8,4 x 21,60 x 80

How to order see page M.71 - Sposób zamawiania, patrz strona M.71

Specify Ball Seat Positions- Prosz okre li pozycj dla wybrania pod kulk

Alternative shapes available (see page M.64,M.65)- Inne kształty- (patrz strony M.64,M.65)

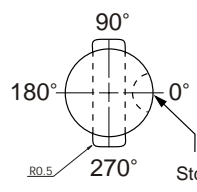

AELL

Std ball position 0°
Standardowa pozycja kulki: 0°

Type AL

ALTERNATIVE LENGTH SPECIFY
- Inna długość -
(okre li)



Ejector type
Stempel z wyrzutnikiem

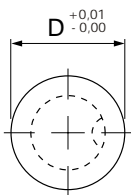

AEHT

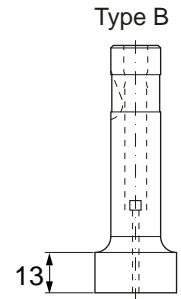
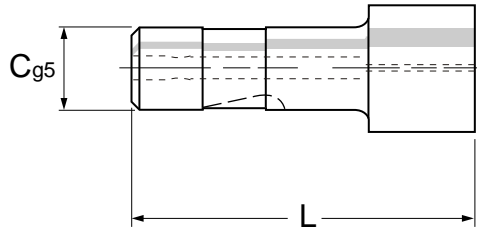

Overall standard lengths 56 up to 125mm
Całkowita standardowa długość 56- 125mm

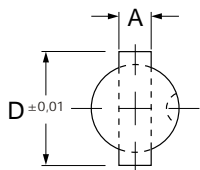

AEHR

Symbol					Min.	Max.
AEHT	AEHR	AEHF	AEHW	AEHL	C	A D
AEHT10	AEHR10	AEHF10	AEHW10	AEHL10	10	10,0 - 24,0
AEHT13	AEHR13	AEHF13	AEHW13	AEHL13	13	10,0 - 32,0
AEHT16	AEHR16	AEHF16	AEHW16	AEHL16	16	10,0 - 38,0
AEHT20	AEHR20	AEHF20	AEHW20	AEHL20	20	10,0 - 38,0
AEHT25	AEHR25	AEHF25	AEHW25	AEHL25	25	15,0 - 45,0
AEHT32	AEHR32	AEHF32	AEHW32	AEHL32	32	15,0 - 45,0
AEHT40	AEHR40	AEHF40	AEHW40	AEHL40	40	15,0 - 50,0

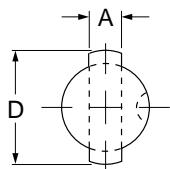
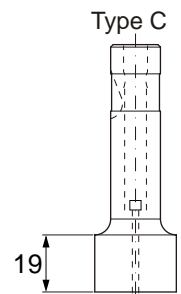

AEHF

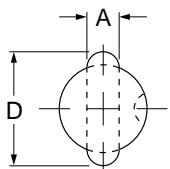

AEHW

Example order- Przykładowe zamówienie:

AEHR16C 8,4 x 21,60 x 80

How to order see page M.71 - Sposób zamawiania, patrz strona M.71

Specify Ball Seat Positions- Prosz okre li pozycj dla wybrania pod kulk

Alternative shapes available (see page M.64,M.65)- Inne kształty- (patrz strony M.64,M.65)

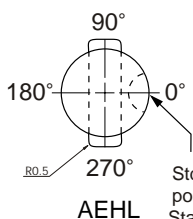
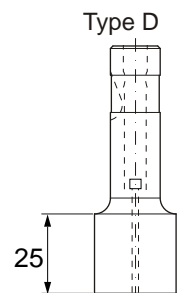

AEHL

Std ball position 0°
Standardowa pozycja kulki: 0°

Type AL

ALTERNATIVE LENGTH SPECIFY
- Inna długość - (okre li)

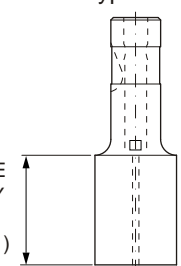

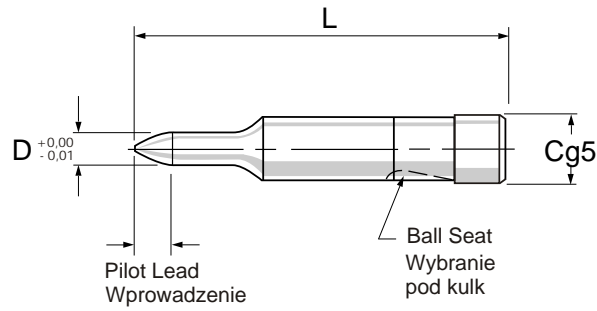

Overall standard length 56 up to 125mm
Standardowa długość całkowita 56 do 125mm

Light Duty Do niskich obciążeń		Heavy Duty Do wysokich obciążeń	
Symbol	C	Symbol	C
LBP6	6		
LBP10	10	HBP10	10
LBP13	13	HBP13	13
LBP16	16	HBP16	16
LBP20	20	HBP20	20
LBP25	25	HBP25	25
LBP32	32	HBP32	32
LBP38	38	HBP38	38

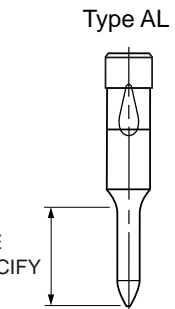
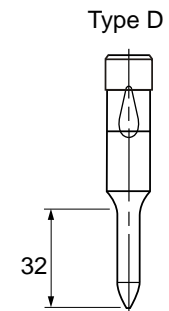
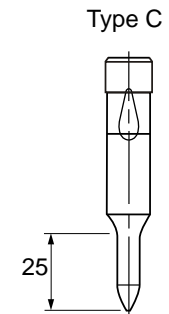
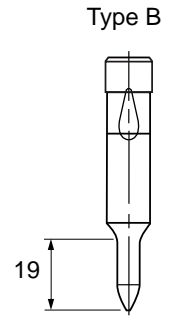

ALTERNATIVE
LENGTH SPECIFY
- Inna długość
(określić)

Example order- Przykładowe zamówienie:
HBP13B x 9 x 60
How to order see page M.71 - Sposób zamawiania, patrz strona M.71

D	Pilot Lead Wprowadzenie
2,3-6,0	4
6,01-10,0	6
10,01-13,0	8
13,01-18,0	10
18,01-25,0	13
25,01-40,0	16

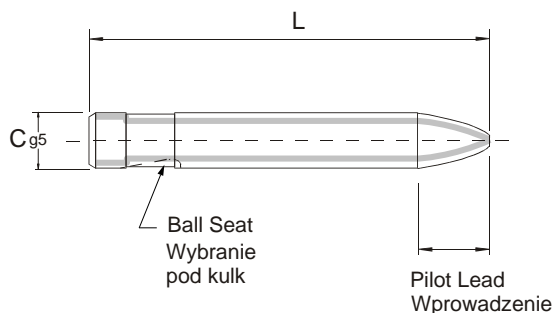

Overall standard length 56 up to 125mm
Standardowa długość całkowita 56 do 125mm

Light Duty Do niskich obciążeń		
Symbol		Pilot Lead wprowadzenie
LBPP6	6	4
LBPP10	10	6
LBPP13	13	8
LBPP16	16	8
LBPP20	20	10
LBPP25	25	13
LBPP32	32	13
LBPP38	38	16

Heavy Duty Do wysokich obciążeń		
Symbol		Pilot Lead wprowadzenie
HBPP10	10	6
HBPP13	13	8
HBPP16	16	8
HBPP20	20	10
HBPP25	25	13
HBPP32	32	13
HBPP40	40	16

Example order- Przykładowe zamówienie:
HBPP13 x 60

How to order see page M.71 - Sposób zamawiania, patrz strona M.71

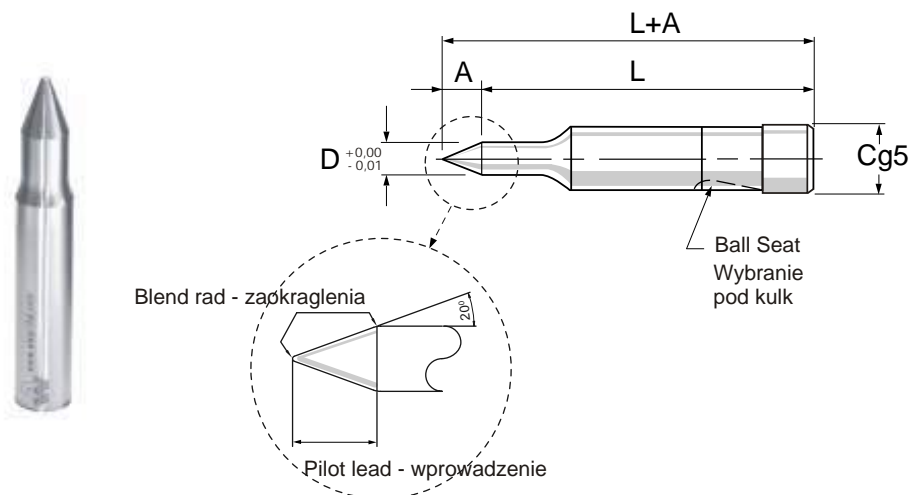

Overall standard length L= 56 up to 125mm
Standardowa długość L= 56 do 125mm

Light Duty Ball Seat Wybranie pod kulkę do niskich obciążeń			
Symbol	C	D	A
LBAPP10	10	5,0 - 10,0	6
LBAPP13	13	9,0 - 13,0	8
LBAPP16	16	12,0 - 16,0	8
LBAPP20	20	15,0 - 20,0	10
LBAPP25	25	19,0 - 25,0	13
LBAPP32	32	24,0 - 32,0	13
LBAPP38	38	30,0 - 38,0	16

Heavy Duty Ball Seat Wybranie pod kulkę do wysokich obciążeń			
Symbol	C	D	A
HBAPP10	10	5,0 - 10,0	6
HBAPP13	13	9,0 - 13,0	8
HBAPP16	16	12,0 - 16,0	8
HBAPP20	20	15,0 - 20,0	10
HBAPP25	25	19,0 - 25,0	13
HBAPP32	32	24,0 - 32,0	13
HBAPP40	40	30,0 - 40,0	16

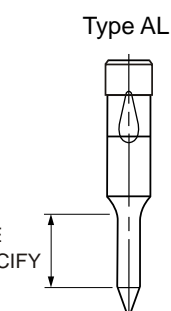
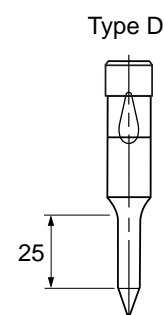
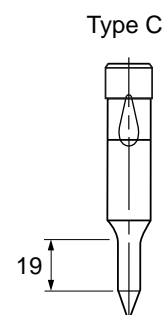
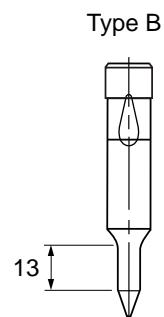

ALTERNATIVE
LENGTH SPECIFY
- Inna długość
(określić)

Example order- Przykładowe zamówienie:

LBPP 13D x 10,1 x 80 L= 80 + A

HBPP 16C x 15,5 x 100

How to order see page M.71 - Sposób zamawiania, patrz strona M.71

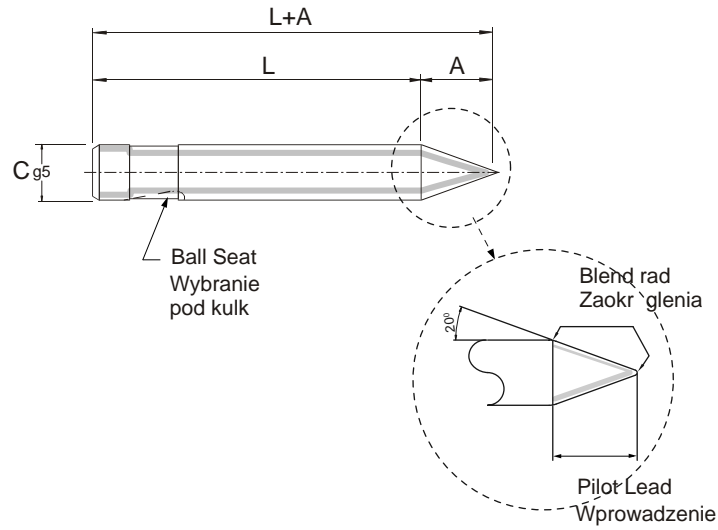

Overall standard length $L = 56$ up to 125mm
Standardowa długość $L = 56$ do 125mm

Light Duty Do niskich obciążeń		
Symbol		Pilot Lead wprowadzenie
LBAP6	6	4
LBAP10	10	6
LBAP13	13	8
LBAP16	16	8
LBAP20	20	10
LBAP25	25	13
LBAP32	32	13
LBAP38	38	16

Heavy Duty Do wysokich obciążeń		
Symbol		Pilot Lead wprowadzenie
HBAP10	10	6
HBAP13	13	8
HBAP16	16	8
HBAP20	20	10
HBAP25	25	13
HBAP32	32	13
HBAP40	40	16

Example order- Przykładowe zamówienie:

LBAP 6 x 90 $L = 90 + A$

HBAP 32 x 110

How to order see page M.71 - Sposób zamawiania, patrz strona M.71

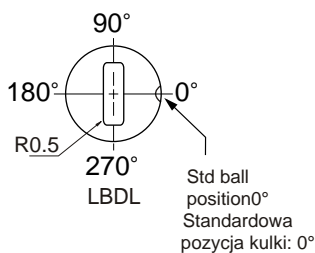
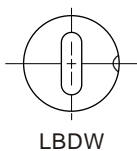
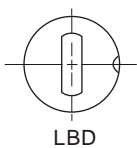
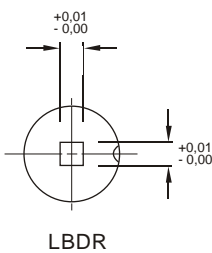
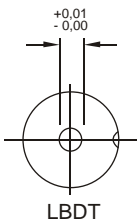
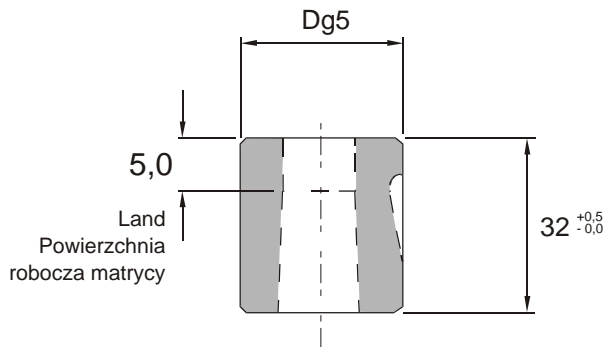

Symbol					D
LBDT13	LBDR13	LBDF13	LBDW13	LBDL13	13
LBDT16	LBDR16	LBDF16	LBDW16	LBDL16	16
LBDT20	LBDR20	LBDF20	LBDW20	LBDL20	20
LBDT25	LBDR25	LBDF25	LBDW25	LBDL25	25
LBDT32	LBDR32	LBDF32	LBDW32	LBDL32	32
LBDT38	LBDR38	LBDF38	LBDW38	LBDL38	138

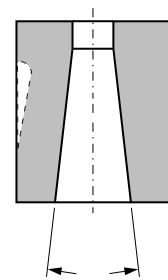

Tapper recess
Wybieg sto kowy

Alternative land lengths readily available (see page M.66)
Inna wysokość powierzchni roboczej na życzenie (patrz strona M.66)
Alternative shapes available (see page M.64, M.65)
Inne kształty - (patrz strony M.64, M.65)
Taper recess supplied unless specified otherwise
Tuleje robione są z wybiegiem sto kowym, o ile nie określono inaczej

Example order - Przykładowe zamówienie:

LBDT13 x 5,01 x 32

LBDR38 x 8,0 x 15 x 32

How to order see page M.71 - Sposób zamawiania, patrz strona M.71

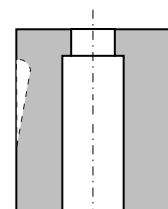

Counterbore recess
Wybieg cylindryczny

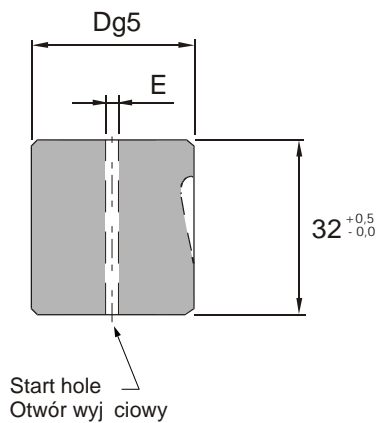

Symbol	D	E
LBDB13	13	1,0
LBDB16	16	1,0
LBDB20	20	1,5
LBDB25	25	1,5
LBDB32	32	1,5
LBDB38	38	2,0

Example order- Przykładowe zamówienie:
LBDB13

How to order see page M.71 - Sposób zamawiania, patrz strona M.71

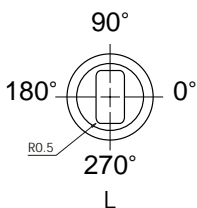
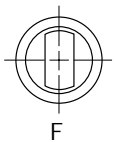
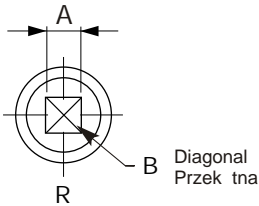
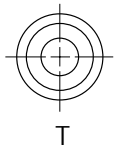
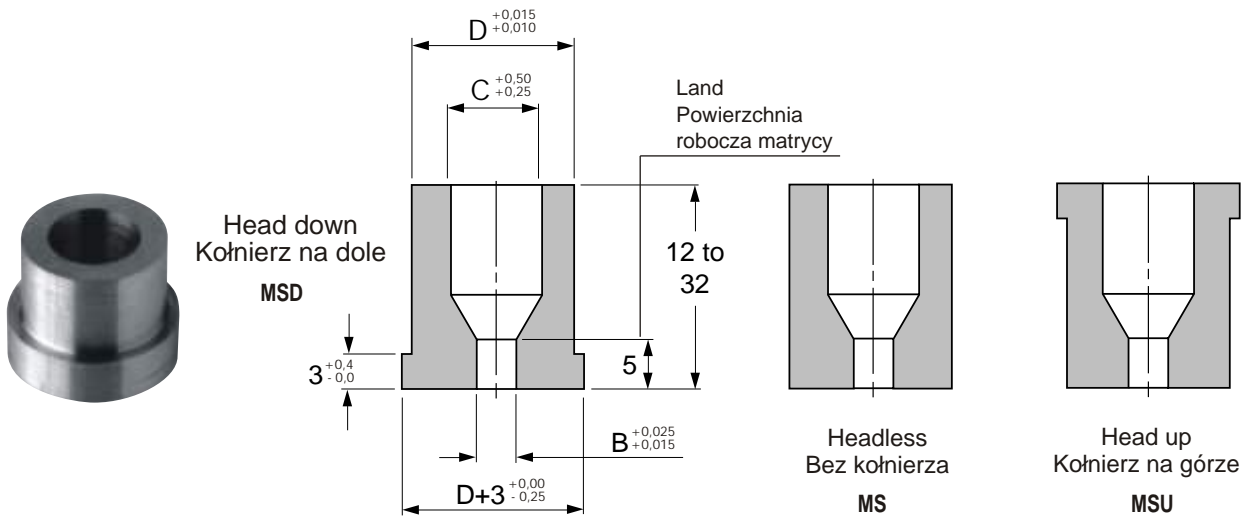

Alternative shapes, body dia., Overall length and land lengths available
Inne kształty, średnica zewnętrzna, całkowita wysokość i wysokość powierzchni roboczej dostępna na życzenie.

	Symbol	D	B	C
MSD*6	MS*6 MSU*6	6	1,5-3,0	3,0
MSD*8	MS*8 MSU*8	8	2,0-4,5	4,5
MSD*10	MS*10 MSU*10	10	3,0-6,0	6,0
MSD*13	MS*13 MSU*13	13	4,0-8,0	8,0
MSD*16	MS*16 MSU*16	16	5,0-9,0	9,0
MSD*19	MS*19 MSU*19	19	7,0-11,0	11,0
MSD*20	MS*20 MSU*20	20	7,0-12,0	12,0
MSD*22	MS*22 MSU*22	22	8,0-14,0	14,0
MSD*25	MS*25 MSU*25	25	8,0-17,0	17,0
MSD*32	MS*32 MSU*32	32	8,0-22,0	22,0
MSD*35	MS*35 MSU*35	35	9,0-25,0	25,0
MSD*38	MS*38 MSU*38	38	9,0-28,0	28,0

* - insert shape code
-rozmiar wstawki symbol kształtu

Location flats if required please specify as shown on page M.67, M.68
Zabezpieczenie przed obrotem na życzenie (patrz str. M.67, M.68)
Note: the shape must not exceed dia. C
Uwaga: rozmiar kształtu nie może przekroczyć średnicy C

Imperial sizes also available
Wszystkie wymiary dostępne także w wersji calowej.

Example order- Przykładowe zamówienie:

MSUR10 3,0 x 4,0 18
MSDW25 8,0 x 12,5 32

How to order see page M.71 - Sposób zamawiania, patrz strona M.71

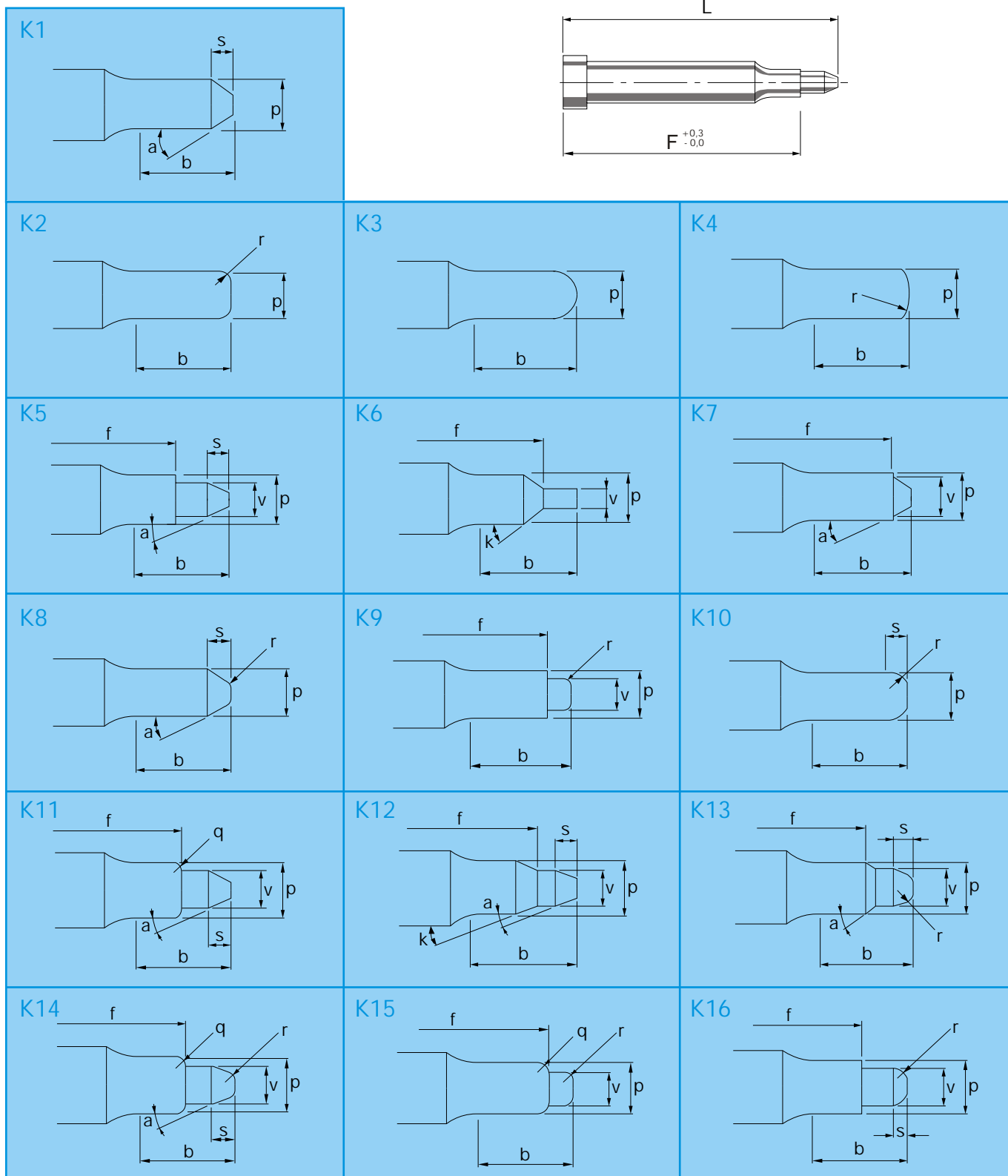

To order specify- Aby zamówić proszę określić :

Symbol No. -Symbol

Dimensions- Wymiary

Punch Blank required- Półfabrykat stempła

Overall length- Długość całkowita

See page M.7 and M.46 for M or MAP symbols

Aby uzyskać symbol półfabrykatu M lub MAP -patrz strony M.7 i M.46

Other forms available- Inne kształty na życzenie

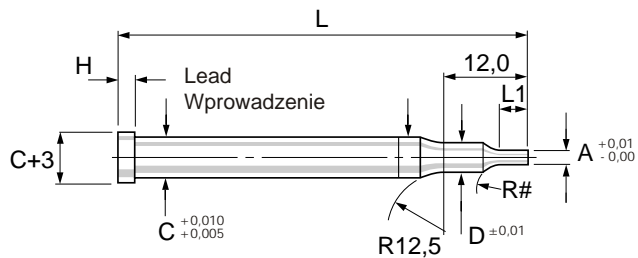

Specify if angle required instead of radius
Prosz okre li czy zamiast promienia wymagane jest odsadzenie sto kowe
Any alternative dimensions to the above can be specified
Inne wymiary na yczenie.

Symbol	ScrewThread Gwint	A	C	D	L ₁	H	L
PH2	M2	1,1	3,0	1,65	1,5	4,2*	s o
PH2,5	M2,5	1,5	3,0	2,10	2,0	4,2*	p k
PH3	M3	1,8	3,0	2,55	2,5	4,2*	e r
PH4	M4	2,3	4,0	3,35	3,0	4,2*	c e
PH5	M5	3,0	5,0	4,25	3,0	4,2*	i l
PH6	M6	3,5	6,0	5,10	3,0	5,0	f i
PH8	M8	4,9	8,0	6,85	4,0	5,0	y

* 5 mm head thickness available

*Główka o grubo ci 5 mm na yczenie.

Example order- Przykładowe zamówienie:

PH4 75

How to order see page M.71 - Sposób zamawiania, patrz strona M.71

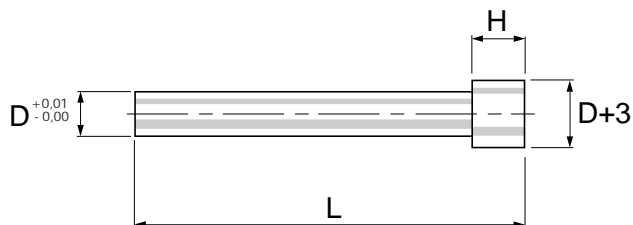

Any length up to 125mm and alternative head thickness readily available
Dostępne są długości do 125mm i główki o innej grubości

Symbol	D Increments 0,01 mm Przyrost co 0,01 mm	H
MAP	1,00-5,99	4,2*
MAP	6,00-18,00	5,0
MAP	18,01-over / i więcej	6,4*

*5 mm head thickness available

*Główka o grubości 5 mm na życzenie.

Example order- Przykładowe zamówienie:

For 19,45mm dia. punch 100 long=MAP19,45 x 100

Dla stempla o średnicy trzonu 19,45 i długości 100mm = MAP19,45 x 100

How to order see page M.71 - Sposób zamawiania, patrz strona M.71

Imperial sizes also available

Wszystkie wymiary dostępne także w wersji calowej

Type DA

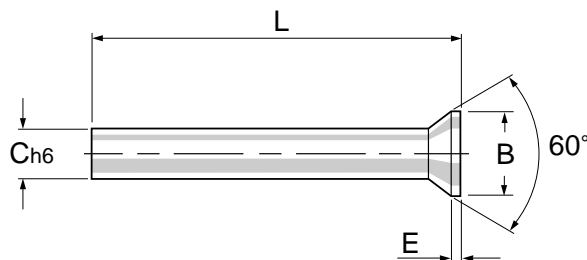

Type A

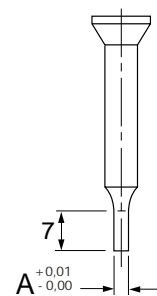

Type B

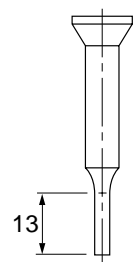

Type C

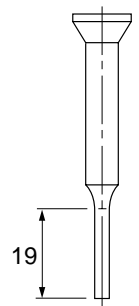

Type D

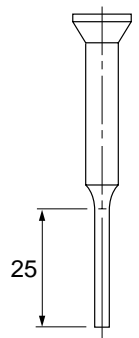

Type AL

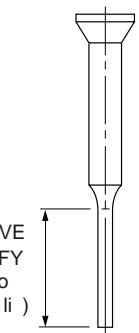

Stock length up to 100mm- Długość do 100 mm na magazynie.
Intermediate and longer point lengths available- Pośrednie lub
większe długości na życzenie.
Any alternative dimensions to be above can be specified- Inne
wymiarowe na życzenie.
Alternative length specify- Inna długość (określić)

C	B	E
1,0 - 1,1	1,8	0,5
1,15 - 1,3	2,0	0,5
1,35 - 1,5	2,2	0,5
1,55 - 1,7	2,5	0,5
1,75 - 1,9	2,8	0,5
1,95 - 2,0	3,0	0,5
2,05 - 2,2	3,2	0,5
2,25 - 2,5	3,5	0,5
2,55 - 2,95	4,0	0,5
3,0 - 3,4	4,5	0,5
3,5 - 3,9	5,0	0,5
4,0 - 4,4	5,5	0,5
4,5 - 4,9	6,0	0,5
5,0 - 5,4	6,5	0,5
5,5 - 5,9	7,0	0,5
6,0 - 6,4	8,0	0,5
6,5 - 7,4	9,0	1,0
7,5 - 8,4	10,0	1,0
8,5 - 9,4	11,0	1,0
9,5 - 10,4	12,0	1,0
10,5 - 11,4	13,0	1,0
11,5 - 12,4	14,0	1,0
12,5 - 13,4	15,0	1,0
13,5 - 14,4	16,0	1,0
14,5 - 15,4	17,0	1,0



DAT

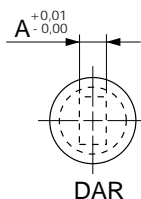

DAR

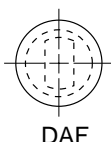

DAF

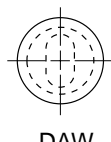

DAW

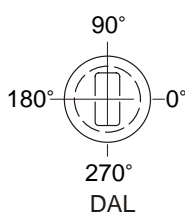

DAL

Example order- Przykładowe zamówienie:

DAT10C x 5,5x70

DWF13A x 10,0x4,0x70

DA6x 100 BLANK

How to order see page M.71 - Sposób zamawiania, patrz strona M.71

Alternative shapes available, (see page M.64,M.65)- Inne kształty
na życzenie- (patrz strony M.64,M.65)

Punch Quills (see page M.54)- Oprawki stemplowe (patrz str. M.54)

ALTERNATIVE
LENGTH SPECIFY
- Inna długość
(określić)

DIN 9861 / ISO 6752

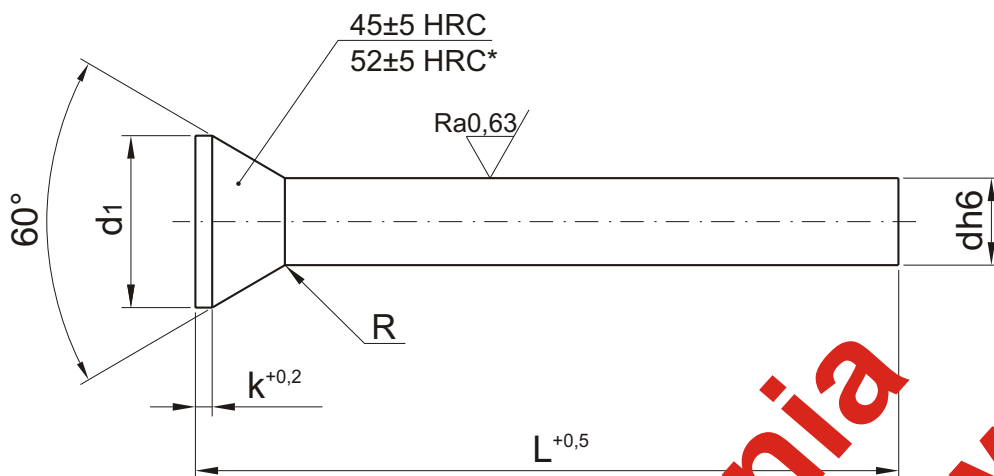

Mat. 1.2210 - 62±2HRC
1.3343 - 64±2HRC

d	d1	k	NR KAT.			d	d1	k	NR KAT.		
			L						L		
			71	80	100				71	80	100
1,0	1,8	0,5	ND-010071	ND-010080	ND-010100	3,1	4,5	0,5	ND-031071	ND-031080	ND-031100
1,1			ND-011071	ND-011080	ND-011100	3,2			ND-032071	ND-032080	ND-032100
1,2	ND-012071		ND-012080	ND-012100	3,3	ND-033071			ND-033080	ND-033100	
1,3	ND-013071		ND-013080	ND-013100	3,4	ND-034071			ND-034080	ND-034100	
1,4	ND-014071		ND-014080	ND-014100	3,5	ND-035071			ND-035080	ND-035100	
1,5	ND-015071		ND-015080	ND-015100	3,6	ND-036071			ND-036080	ND-036100	
1,6	ND-016071		ND-016080	ND-016100	3,7	ND-037071			ND-037080	ND-037100	
1,7	ND-017071		ND-017080	ND-017100	3,8	ND-038071			ND-038080	ND-038100	
1,8	ND-018071		ND-018080	ND-018100	3,9	ND-039071			ND-039080	ND-039100	
1,9	ND-019071		ND-019080	ND-019100	4,0	ND-040071			ND-040080	ND-040100	
2,0	3,0	ND-020071	ND-020080	ND-020100	4,1	ND-041071	ND-041080	ND-041100			
2,1		ND-021071	ND-021080	ND-021100	4,2	ND-042071	ND-042080	ND-042100			
2,2	3,2	ND-022071	ND-022080	ND-022100	4,3	ND-043071	ND-043080	ND-043100			
2,3		ND-023071	ND-023080	ND-023100	4,4	ND-044071	ND-044080	ND-044100			
2,4	3,5	ND-024071	ND-024080	ND-024100	4,5	ND-045071	ND-045080	ND-045100			
2,5		ND-025071	ND-025080	ND-025100	4,6	ND-046071	ND-046080	ND-046100			
2,6	4,0	ND-026071	ND-026080	ND-026100	4,7	ND-047071	ND-047080	ND-047100			
2,7		ND-027071	ND-027080	ND-027100	4,8	ND-048071	ND-048080	ND-048100			
2,8	4,0	ND-028071	ND-028080	ND-028100	4,9	ND-049071	ND-049080	ND-049100			
2,9		ND-029071	ND-029080	ND-029100	5,0	ND-050071	ND-050080	ND-050100			
3,0	4,5	ND-030071	ND-030080	ND-030100	5,1	ND-051071	ND-051080	ND-051100			

Example order- Przykładowe zamówienie:

ND-080071 - materiał 1.2210
- materiał 1.2210
ND-080071S - materiał 1.3343
- materiał 1.3343

Note: 1) Punches with diameters from d=1,0 to 1,9 mm available only in 1.3343 steel.
Uwaga: Stemple o średnicy od=1,0 do 1,9 mm wykonujemy wyłącznie z materiału gat. 1.3343

2) Other lengths and diameters on request.
Inne wymiary długości i średnic na życzenie.

3)*Applies to 1.3343 material
Dotyczy materiału gat. 1.3343

DIN 9861 / ISO 6752

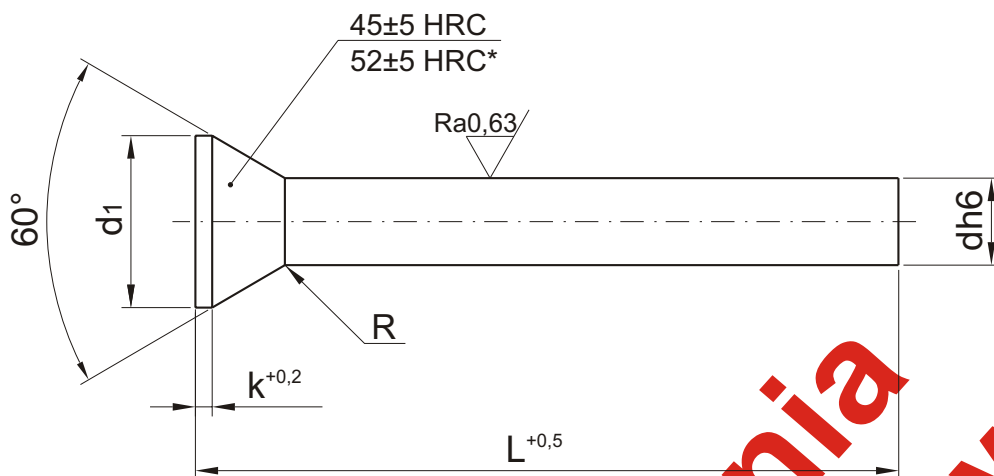

Mat. 1.2210 - 62±2HRC
1.3343 - 64±2HRC

d	d1	k	NR KAT.			d	d1	k	NR KAT.		
			71	80	100				71	80	100
5,2	6,5	0,5	ND-052071	ND-052080	ND-052100	10,5	13,0	1,0	ND-105071	ND-105080	ND-105100
5,3			ND-053071	ND-053080	ND-053100	11,0	14,0		ND-110071	ND-110080	ND-110100
5,4			ND-054071	ND-054080	ND-054100	11,5			ND-115071	ND-115080	ND-115100
5,5	ND-055071		ND-055080	ND-055100	12,0	15,0	ND-120071		ND-120080	ND-120100	
5,6	ND-056071		ND-056080	ND-056100	12,5		ND-125071		ND-125080	ND-125100	
5,7	7,0		ND-057071	ND-057080	ND-057100	13,0	16,0		ND-130071	ND-130080	ND-130100
5,8	ND-058071		ND-058080	ND-058100	13,5	ND-135071			ND-135080	ND-135100	
5,9	ND-059071		ND-059080	ND-059100	14,0	17,0	ND-140071		ND-140080	ND-140100	
6,0	ND-060071		ND-060080	ND-060100	14,5		ND-145071		ND-145080	ND-145100	
6,1	8,0		1,0	ND-061071	ND-061080	ND-061100	15,0		18,0	ND-150071	ND-150080
6,2		ND-062071		ND-062080	ND-062100	15,5	ND-155071	ND-155080		ND-155100	
6,3		ND-063071		ND-063080	ND-063100	16,0	19,0	ND-160071	ND-160080	ND-160100	
6,4	ND-064071	ND-064080		ND-064100	16,5	ND-165071		ND-165080	ND-165100		
6,5	9,0	ND-065071		ND-065080	ND-065100	17,0	20,0	ND-170071	ND-170080	ND-170100	
7,0	ND-070071	ND-070080		ND-070100	17,5	ND-175071		ND-175080	ND-175100		
7,5	10,0	ND-075071		ND-075080	ND-075100	18,0	21,0	ND-180071	ND-180080	ND-180100	
8,0	ND-080071	ND-080080		ND-080100	18,5	ND-185071		ND-185080	ND-185100		
8,5	11,0	ND-085071		ND-085080	ND-085100	19,0	22,0	ND-190071	ND-190080	ND-190100	
9,0	ND-090071	ND-090080		ND-090100	19,5	ND-195071		ND-195080	ND-195100		
9,5	12,0	ND-095071	ND-095080	ND-095100	20,0	ND-200071	ND-200080	ND-200100			
10,0	ND-100071	ND-100080	ND-100100								

Example order:
Przykładowe zamówienie:

ND-080071 - materiał 1.2210
- materiał 1.2210
ND-080071S - materiał 1.3343
- materiał 1.3343

Note: 1) Punches with diameters from d=16,5 to 20,0 mm
Uwaga: 1) Ścierniki o średnicach od d=16,5 do 20,0 mm

available only in 1.3343 steel.
wykonujemy wyłącznie z materiału gat. 1.3343

2) Other lengths and diameters on request.
Inne wymiary długości i średnic na życzenie.

3)*Applies to 1.3343 material
Dotyczy materiału gat. 1.3343

DIN 9861

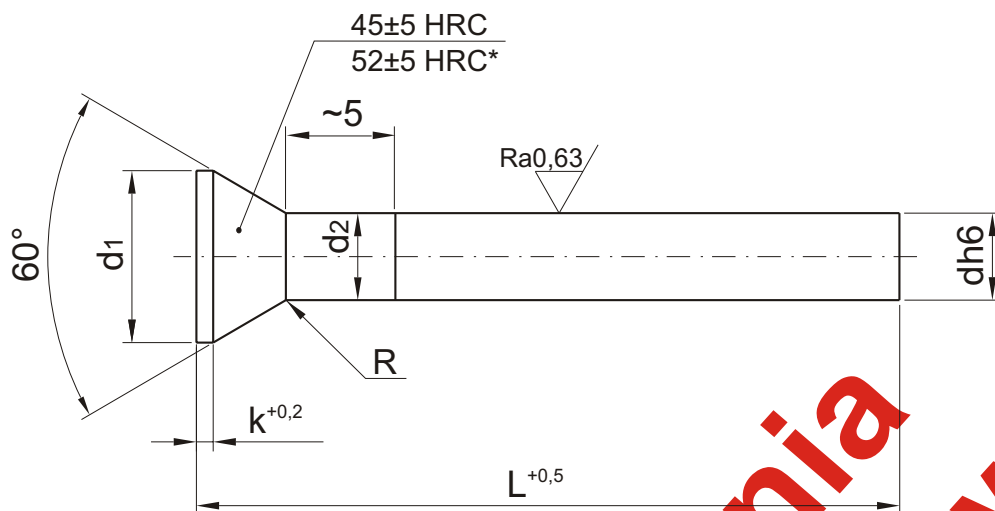

Mat. 1.2210 - 62±2HRC
1.3343 - 64±2HRC

d	d1	k	NR KAT.			d	d1	k	NR KAT.		
			L						L		
			71	80	100				71	80	100
1,0	1,8	0,5	NDA-010071	NDA-010080	NDA-010100	3,1	4,5	0,5	NDA-031071	NDA-031080	NDA-031100
1,1			NDA-011071	NDA-011080	NDA-011100	3,2			NDA-032071	NDA-032080	NDA-032100
1,2	NDA-012071		NDA-012080	NDA-012100	3,3	NDA-033071			NDA-033080	NDA-033100	
1,3	NDA-013071		NDA-013080	NDA-013100	3,4	NDA-034071			NDA-034080	NDA-034100	
1,4	NDA-014071		NDA-014080	NDA-014100	3,5	NDA-035071			NDA-035080	NDA-035100	
1,5	NDA-015071		NDA-015080	NDA-015100	3,6	NDA-036071			NDA-036080	NDA-036100	
1,6	NDA-016071		NDA-016080	NDA-016100	3,7	NDA-037071			NDA-037080	NDA-037100	
1,7	NDA-017071		NDA-017080	NDA-017100	3,8	NDA-038071			NDA-038080	NDA-038100	
1,8	NDA-018071		NDA-018080	NDA-018100	3,9	NDA-039071			NDA-039080	NDA-039100	
1,9	NDA-019071		NDA-019080	NDA-019100	4,0	NDA-040071			NDA-040080	NDA-040100	
2,0	3,0	0,5	NDA-020071	NDA-020080	NDA-020100	4,1	5,0	0,5	NDA-041071	NDA-041080	NDA-041100
2,1	3,2		NDA-021071	NDA-021080	NDA-021100	4,2			NDA-042071	NDA-042080	NDA-042100
2,2	NDA-022071		NDA-022080	NDA-022100	4,3	NDA-043071			NDA-043080	NDA-043100	
2,3	NDA-023071		NDA-023080	NDA-023100	4,4	NDA-044071			NDA-044080	NDA-044100	
2,4	3,5		NDA-024071	NDA-024080	NDA-024100	4,5			NDA-045071	NDA-045080	NDA-045100
2,5	NDA-025071		NDA-025080	NDA-025100	4,6	NDA-046071			NDA-046080	NDA-046100	
2,6	NDA-026071		NDA-026080	NDA-026100	4,7	NDA-047071			NDA-047080	NDA-047100	
2,7	NDA-027071		NDA-027080	NDA-027100	4,8	NDA-048071			NDA-048080	NDA-048100	
2,8	4,0		NDA-028071	NDA-028080	NDA-028100	4,9			NDA-049071	NDA-049080	NDA-049100
2,9	NDA-029071		NDA-029080	NDA-029100	5,0	NDA-050071			NDA-050080	NDA-050100	
3,0	4,5	NDA-030071	NDA-030080	NDA-030100	5,1	NDA-051071	NDA-051080	NDA-051100			

Example order- Przykładowe zamówienie:

NDA-080071 - materiał 1.2210
- materiał 1.2210

NDA-080071S - materiał 1.3343
- materiał 1.3343

Note:
Uwaga:

1) Punches with diameters from d=1,0 to 1,9 mm available only in 1.3343 steel.
Stemple o średnicy od=1,0 do 1,9 mm wykonujemy wyłącznie z materiału gat. 1.3343

2) Other lengths and diameters on request.
Inne wymiary długości i średnic na życzenie.

3) $d2=d+0,03$

4)*Applies to 1.3343 material
Dotyczy materiału gat. 1.3343

DIN 9861

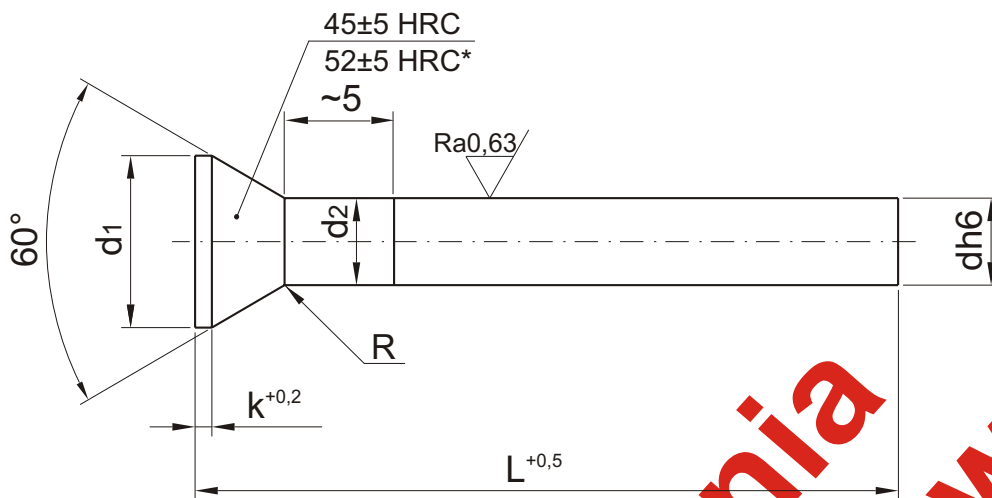

Mat. 1.2210 - 62±2HRC
1.3343 - 64±2HRC

d	d1	k	NR KAT.			d	d1	k	NR KAT.		
			L						L		
			71	80	100				71	80	100
5,2	6,5	0,5	NDA-052071	NDA-052080	NDA-052100	10,5	13,0	1,0	NDA-105071	NDA-105080	NDA-105100
5,3			NDA-053071	NDA-053080	NDA-053100	11,0			NDA-110071	NDA-110080	NDA-110100
5,4			NDA-054071	NDA-054080	NDA-054100	11,5	NDA-115071		NDA-115080	NDA-115100	
5,5	NDA-055071		NDA-055080	NDA-055100	12,0	NDA-120071	NDA-120080		NDA-120100		
5,6	7,0		NDA-056071	NDA-056080	NDA-056100	12,5	15,0		NDA-125071	NDA-125080	NDA-125100
5,7			NDA-057071	NDA-057080	NDA-057100	13,0			NDA-130071	NDA-130080	NDA-130100
5,8			NDA-058071	NDA-058080	NDA-058100	13,5	16,0		NDA-135071	NDA-135080	NDA-135100
5,9	NDA-059071		NDA-059080	NDA-059100	14,0	NDA-140071			NDA-140080	NDA-140100	
6,0	8,0		NDA-060071	NDA-060080	NDA-060100	14,5	17,0		NDA-145071	NDA-145080	NDA-145100
6,1			NDA-061071	NDA-061080	NDA-061100	15,0			NDA-150071	NDA-150080	NDA-150100
6,2		NDA-062071	NDA-062080	NDA-062100	15,5	18,0	NDA-155071	NDA-155080	NDA-155100		
6,3	NDA-063071	NDA-063080	NDA-063100	16,0	NDA-160071		NDA-160080	NDA-160100			
6,4	9,0	NDA-064071	NDA-064080	NDA-064100	16,5	19,0	NDA-165071	NDA-165080	NDA-165100		
6,5		NDA-065071	NDA-065080	NDA-065100	17,0		NDA-170071	NDA-170080	NDA-170100		
7,0		NDA-070071	NDA-070080	NDA-070100	17,5	20,0	NDA-175071	NDA-175080	NDA-175100		
7,5	10,0	NDA-075071	NDA-075080	NDA-075100	18,0		NDA-180071	NDA-180080	NDA-180100		
8,0		NDA-080071	NDA-080080	NDA-080100	18,5	21,0	NDA-185071	NDA-185080	NDA-185100		
8,5		NDA-085071	NDA-085080	NDA-085100	19,0		NDA-190071	NDA-190080	NDA-190100		
9,0	11,0	NDA-090071	NDA-090080	NDA-090100	19,5	22,0	NDA-195071	NDA-195080	NDA-195100		
9,5		NDA-095071	NDA-095080	NDA-095100	20,0		NDA-200071	NDA-200080	NDA-200100		
10,0		NDA-100071	NDA-100080	NDA-100100							

Example order:
Przykładowe zamówienie:
NDA-080071 - materiał 1.2210
- materiał 1.2210
NDA-080071S - materiał 1.3343
- materiał 1.3343

Note: 1) Punches with diameters from d=16,5 to 20,0 mm available only in 1.3343 steel.
Uwaga: Stemple o średnicy od=16,5 do 20,0 mm wykonujemy wyłącznie z materiału gat. 1.3343

- $d_2 = \begin{cases} d+0,03 & \text{dla } d \leq 6,4\text{mm} \\ d+0,04 & \text{dla } d \geq 6,5\text{mm} \end{cases}$
- Other lengths and diameters on request.
Inne wymiary długości i średnic na życzenie.
- *Applies to 1.3343 material
Dotyczy materiału gat. 1.3343

Typ A

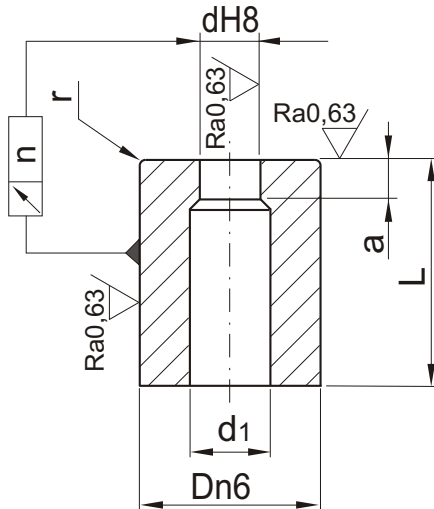

Typ B

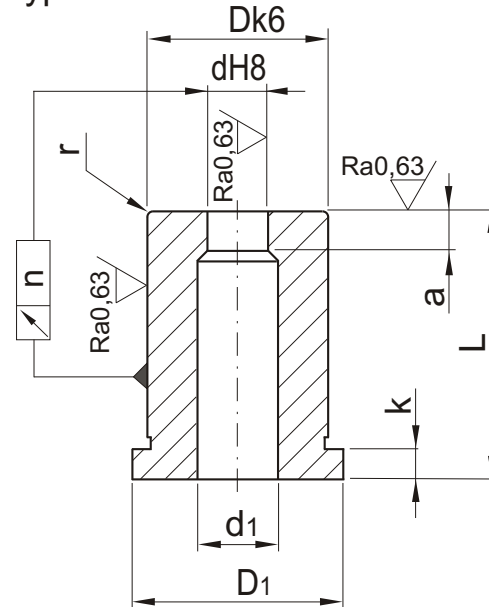

- gradation **d** diameter at 0,1 mm intervals
- stopniowanie średnicy **d** co 0,1 mm

Mat. 1.2210 60±2HRC

d	L	d1	D	D1	a	k	r	n
1,1 - 1,8	20	d+0,6	6	8	3	4	0,3	0,005
	28							
1,9 - 2,6	20		7	9				
	28							
2,7 - 3,3	20		7	9				
	28							
3,4 - 4,0	20	8	10					
	28							
4,1 - 5,0	20	d+1	10	12	4	4	0,6	0,01
	28							
5,1 - 6,0	20		12	14				
	28							
6,1 - 8,0	20		15	17				
	28							
8,1 - 10,0	20		18	20				
	28							
10,1 - 12,0	20		22	24	5	0,8		
	28							
12,1 - 15,0	28		26	28				

Example order:

- d=1,8 ; L=20 type A
Catalog code - **DS02-1820A**
- d=4,0 ; L=28 type B
Catalog code - **DS02-4028B**

Przykłady zamawiania:

- d=1,8 ; L=20 typ A
Nr katalogowy - **DS02-1820A**
- d=4,0 ; L=28 typ B
Nr katalogowy - **DS02-4028B**

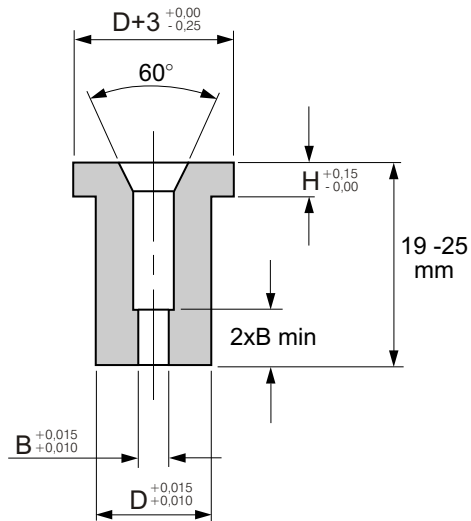

Symbol	B	H	D
MPQ6	1,5-3,0	3*	6,0
MPQ8	3,0-5,0	3*	8,0
MPQ10	3,0-6,0	3*	10,0
MPQ13	5,0-8,0	3*	13,0

Imperial sizes also available- Wymiary dostępne również w calach.

*5mm head thickness available-Główka o grubości 5mm na życzenie.

Example order- Przykładowe zamówienie:
MPQ8 x 3,6x25

WYRZUTNIK

SLUG EJECTOR PINS

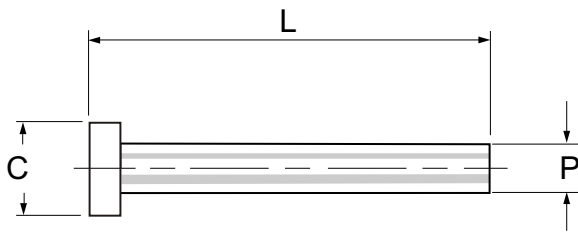

Symbol	P	C	L
EP02	0,020"	0,043"	2"
EP03	0,030"	0,050"	2"
EP04	0,040"	0,066"	2"
EP06	0,060"	0,100"	2"
EP09	0,093"	0,140"	2"

Example order- Przykładowe zamówienie:
Ep09

SPRĘŻYNY WYRZUTNIKA

SLUG EJECTOR SPRINGS

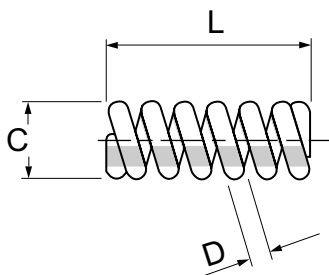

Symbol	C	D	L
ES08	0,080"	0,016"	2"
ES11	0,110"	0,020"	2"
ES15	0,150"	0,025"	2"

Example order- Przykładowe zamówienie:
Es15

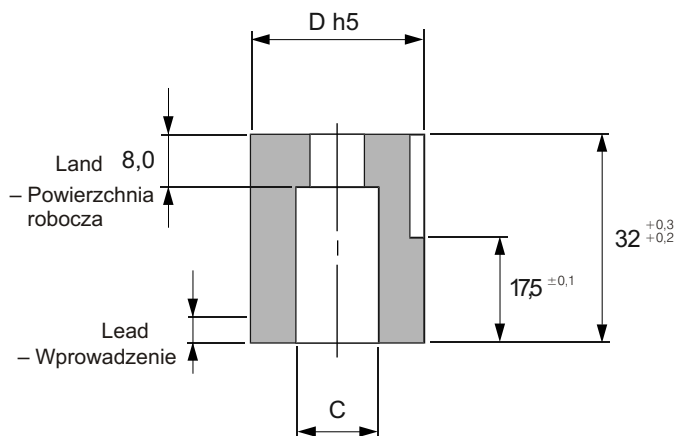

Symbol	φ D	φ C	E
SMD*16	16	8	11,5
SMD*20	20	10	13,5
SMD*25	25	17	16,0
SMD*32	32	22	19,5
SMD*40	40	26	23,5
SMD*50	50	38	28,5

Example order- Przykładowe zamówienie:

SMRP20 4,0x 6,0

How to order see page M.70 - Sposób zamawiania, patrz strona M.70

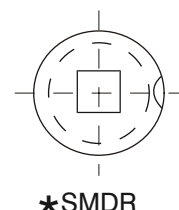
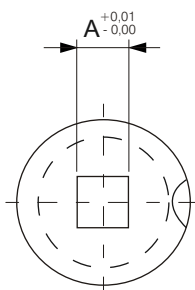

TYPICAL ASSY AFTER REGRIND

Typowe zamocowanie po przeszlifowaniu

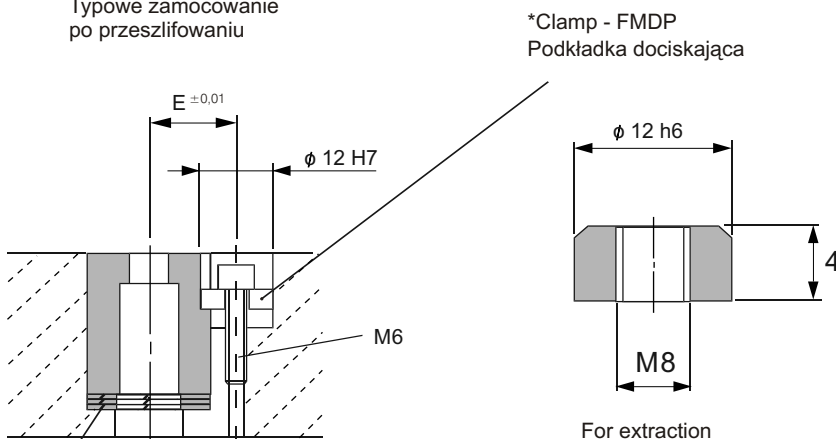

Shims (not supplied)- Podkładki ustalające (nie są częścią zestawu)

*Clamp - FMDP
Podkładka dociskająca

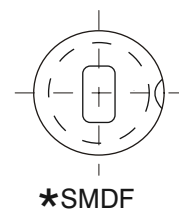
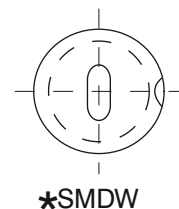

Die Clamp and Cap Head Screw must be ordered if required
Podkładkę dociskową oraz śrubę z łbem walcowym należy zamówić osobno
Alternative shapes available, see main catalog pages M.63, M.64
Inne kształty na życzenie, patrz strony M.63, M.64

Example order- Przykładowe zamówienie:

FMDP x Qty
FMDP x ilość

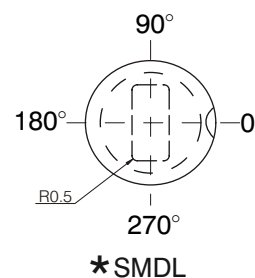

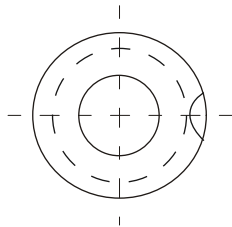
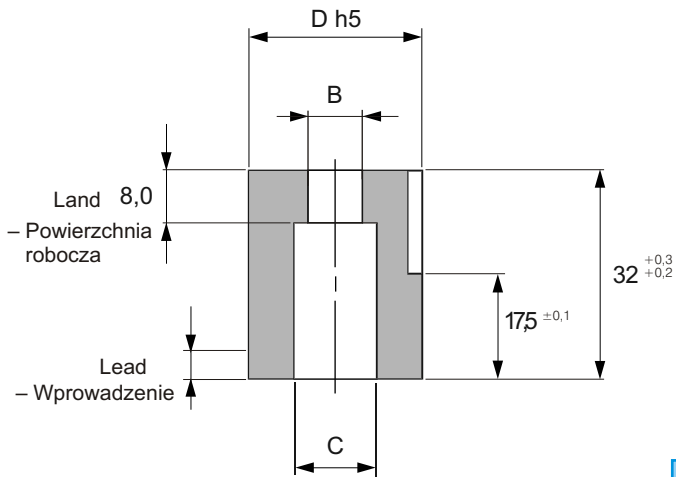

Symbol	φ D	φ C	φ B	E
SMDP16	16	8	3-7	11,5
SMDP20	20	10	7-9	13,5
SMDP25	25	17	9-16	16,0
SMDP32	32	22	16-21	19,5
SMDP40	40	26	21-25	23,5
SMDP50	50	38	25-37	28,5

TYPICAL ASSY AFTER REGRIND

Typowe zamocowanie po przeszlifowaniu

Example order- Przykładowe zamówienie:
SMDP20 x 5,4

How to order see page M.70 - Sposób zamawiania, patrz strona M.70

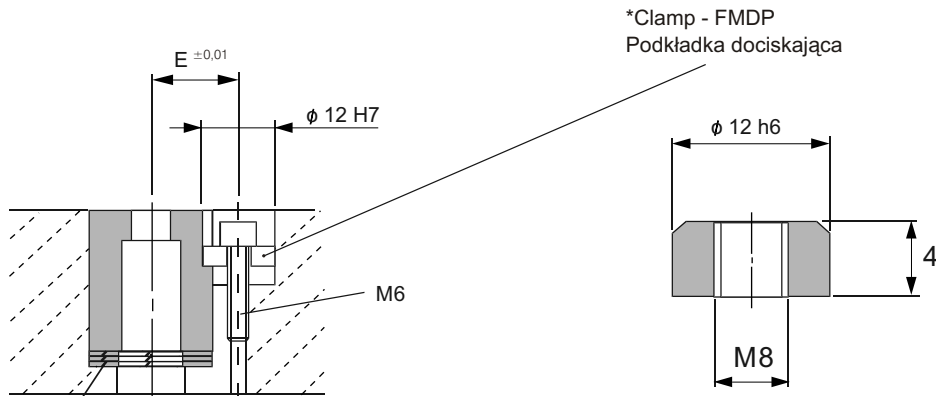

Shims (not supplied)- Podkładki ustalające (nie są częścią zestawu)

For extraction- Dla ułatwienia demontażu

Die Clamp and Cap Head Screw must be ordered if required
Podkładkę dociskową oraz śrubę z łbem walcowym należy zamówić osobno

Example order- Przykładowe zamówienie:
FMDP x Qty
FMDP x ilość

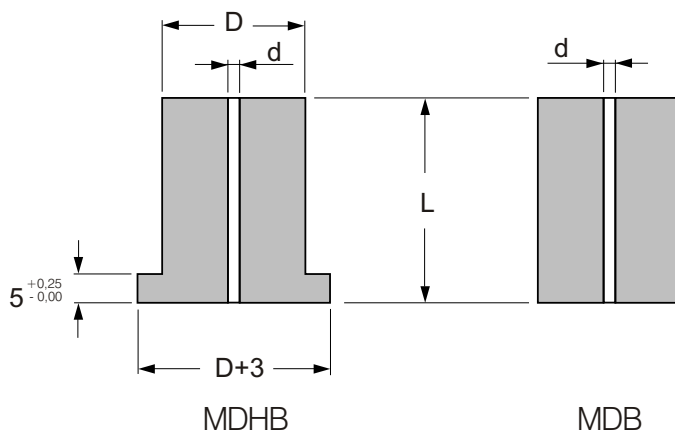

L- Length 12 to 32mm- Wysokość 12 do 32mm
d- Drilled start hole - Średnica otworu wyjściowego do obróbki EDM

Symbol		D	d
MDB5	MDHB5	5	1,0
MDB6	MDHB6	6	
MDB8	MDHB8	8	
MDB10	MDHB10	10	
MDB13	MDHB13	13	
MDB16	MDHB16	16	
MDB19	MDHB19	19	1,5
MDB20	MDHB20	20	
MDB22	MDHB22	22	
MDB25	MDHB25	25	
MDB28	MDHB28	28	
MDB32	MDHB32	32	
MDB35	MDHB35	35	2,0
MDB38	MDHB38	38	
MDB40	MDHB40	40	
MDB42	MDHB42	42	
MDB45	MDHB45	45	
MDB50	MDHB50	50	

Alternative body and bore size available
Location flats if required (see page M.64,M.65)
Imperial sizes also available

Inne rozmiary średnicy zewnętrznej i otworu wyjściowego na życzenie
Zabezpieczenie przed obrotem na życzenie (patrz strony M.66, M.67)
Wszystkie wymiary dostępne także w wersji calowej.

Example order- Przykładowe zamówienie:

6 off MDB13 x 95

4 off MDHB10 x 80

How to order see page M.70 - Sposób zamawiania, patrz strona M.70

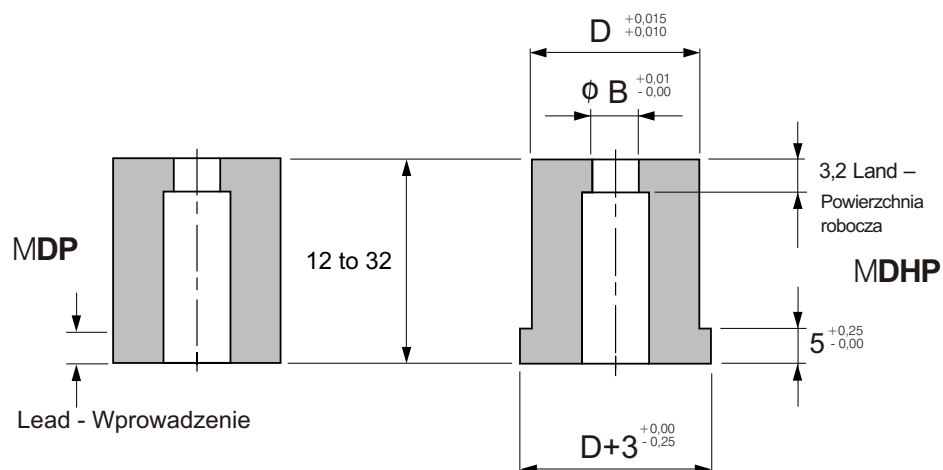

Alternative body diameter, overall length and land lengths readily available

Na życzenie dostępne są inne wielkości średnicy zewnętrznej, długości całkowitej i wysokości powierzchni roboczej.

Symbol	D	B	
MDP5	MDHP5	5	1,5-3,0
MDP6	MDHP6	6	1,5-4,0
MDP8	MDHP8	8	2,0-5,0
MDP10	MDHP10	10	2,0-6,5
MDP13	MDHP13	13	3,0-8,5
MDP16	MDHP16	16	6,0-10,5
MDP19	MDHP19	19	6,0-11,5
MDP20	MDHP20	20	8,0-13,5
MDP22	MDHP22	22	8,0-15,0
MDP25	MDHP25	25	12,0-17,0
MDP28	MDHP28	28	12,0-22,0
MDP32	MDHP32	32	12,0-26,0
MDP35	MDHP35	35	12,0-28,0
MDP38	MDHP38	38	12,0-30,0
MDP40	MDHP40	40	16,0-32,0
MDP42	MDHP42	42	16,0-33,0
MDP45	MDHP45	45	16,0-34,0
MDP50	MDHP50	50	16,0-36,0

Example order- Przykładowe zamówienie:

MDHP10 5,0x 19

How to order see page M.70 - Sposób zamawiania, patrz strona M.70

Imperial sizes also available- Wszystkie wymiary dostępne także w wersji calowej.

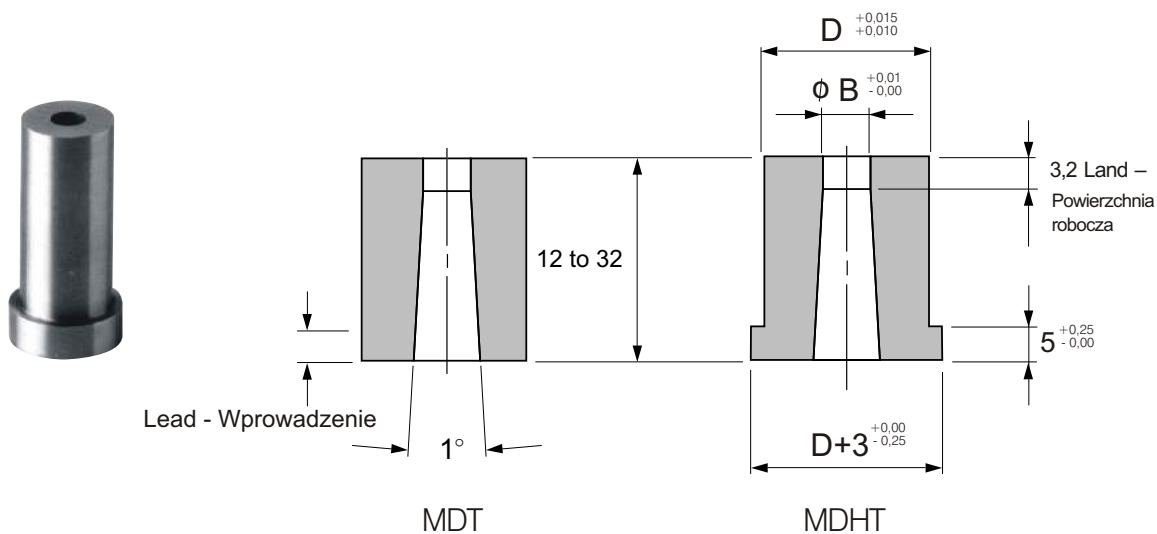

Alternative body diameter, overall length and land lengths readily available

Na życzenie dostępne są inne wielkości średnicy zewnętrznej, długości całkowitej i wysokości powierzchni roboczej.

Symbol	D	B
MDT5 MDHT5	5	2,0-3,0
MDT6 MDHT6	6	2,0-4,0
MDT8 MDHT8	8	2,0-5,0
MDT10 MDHT10	10	2,0-6,5
MDT13 MDHT13	13	3,0-8,5
MDT16 MDHT16	16	6,0-10,5
MDT19 MDHT19	19	6,0-11,5
MDT20 MDHT20	20	8,0-13,5
MDT22 MDHT22	22	8,0-15,0
MDT25 MDHT25	25	12,0-17,0
MDT28 MDHT28	28	12,0-22,0
MDT32 MDHT32	32	12,0-26,0
MDT35 MDHT35	35	12,0-28,0
MDT38 MDHT38	38	12,0-30,0
MDT40 MDHT40	40	16,0-32,0
MDT42 MDHT42	42	16,0-33,0
MDT45 MDHT45	45	16,0-34,0
MDT50 MDHT50	50	16,0-36,0

Example order- Przykładowe zamówienie:

MDHT10 5,0x 19

How to order see page M.70 - Sposób zamawiania, patrz strona M.70

Imperial sizes also available- Wszystkie wymiary dostępne także w wersji calowej.

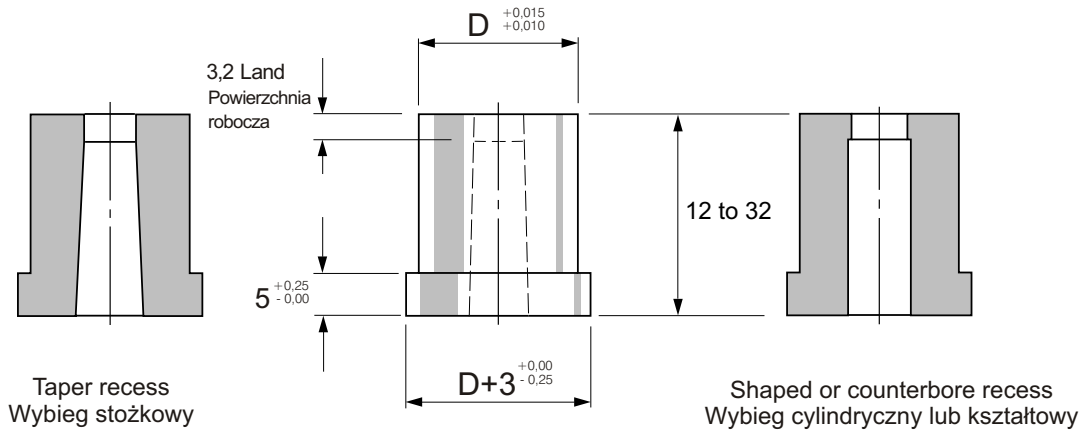

Body diameter, overall length and land lengths readily available
Na życzenie dostępne są inne wielkości średnicy zewnętrznej, długości całkowitej i wysokości powierzchni roboczej matrycy.

Headless dies
Tuleja bez kołnierza

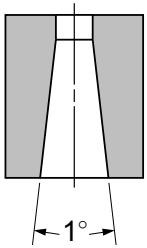

Taper recess
Wybieg stożkowy

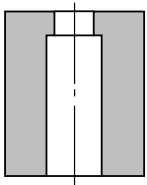

Counterbore recess
Wybieg cylindryczny

Symbol								
Headless Dies Bez kołnierza				Headed Dies Z kołnierzem				D
MDR8	MDF8	MDW8	MDL8	MDHR8	MDHF8	MDHW8	MDHL8	8
MDR10	MDF10	MDW10	MDL10	MDHR10	MDHF10	MDHW10	MDHL10	10
MDR13	MDF13	MDW13	MDL13	MDHR13	MDHF13	MDHW13	MDHL13	13
MDR16	MDF16	MDW16	MDL16	MDHR16	MDHF16	MDHW16	MDHL16	16
MDR19	MDF19	MDW19	MDL19	MDHR19	MDHF19	MDHW19	MDHL19	19
MDR20	MDF20	MDW20	MDL20	MDHR20	MDHF20	MDHW20	MDHL20	20
MDR22	MDF22	MDW22	MDL22	MDHR22	MDHF22	MDHW22	MDHL22	22
MDR25	MDF25	MDW25	MDL25	MDHR25	MDHF25	MDHW25	MDHL25	25
MDR28	MDF28	MDW28	MDL28	MDHR28	MDHF28	MDHW28	MDHL28	28
MDR32	MDF32	MDW32	MDL32	MDHR32	MDHF32	MDHW32	MDHL32	32
MDR35	MDF35	MDW35	MDL35	MDHR35	MDHF35	MDHW35	MDHL35	35
MDR38	MDF38	MDW38	MDL38	MDHR38	MDHF38	MDHW38	MDHL38	38
MDR40	MDF40	MDW40	MDL40	MDHR40	MDHF40	MDHW40	MDHL40	40
MDR42	MDF42	MDW42	MDL42	MDHR42	MDHF42	MDHW42	MDHL42	42
MDR45	MDF45	MDW45	MDL45	MDHR45	MDHF45	MDHW45	MDHL45	45
MDR50	MDF50	MDW50	MDL50	MDHR50	MDHF50	MDHW50	MDHL50	50

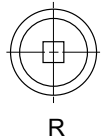

R

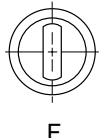

F



W

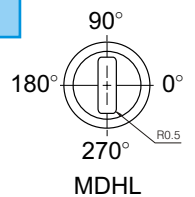

MDHL

Example order- Przykładowe zamówienie:

MDHP10 5,0x 19

How to order see page M.70 - Sposób zamawiania, patrz strona M.70

Taper relief is supplied unless specified otherwise. Locations if required please specify as shown on page M.66, M.67 Alternative shapes see pages M.63, M.64 . Imperial sizes also available.

O ile nie określono inaczej tuleje tnące robione są z wybiegiem stożkowym. Rowki lub zabezpieczenie przed obrotem na życzenie (patrz strony M.66, M.67) Inne kształty, patrz strony M.63, M.64 Wszystkie wymiary dostępne także w wersji calowej.

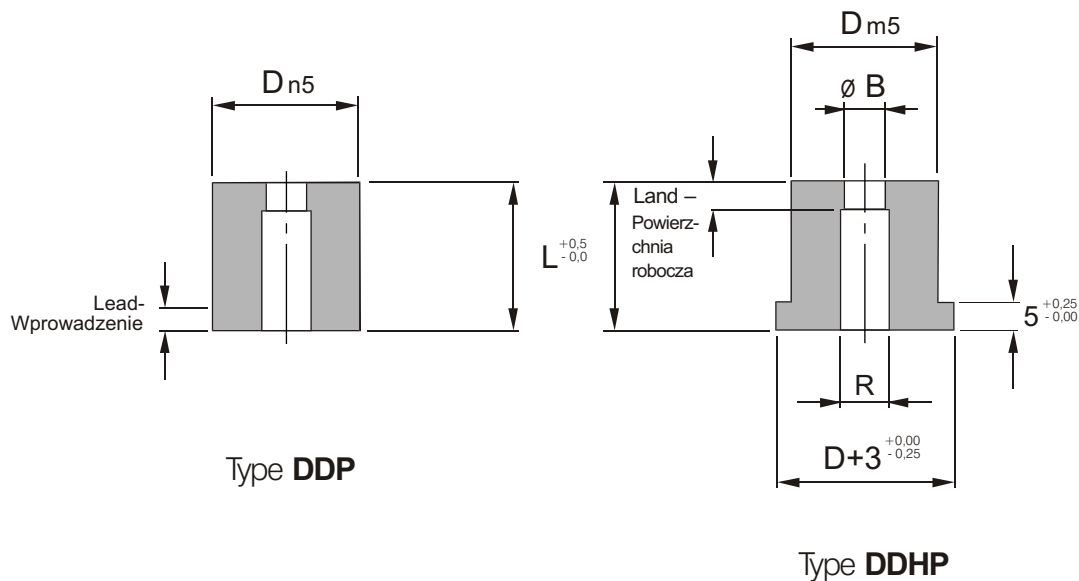

Materiał 1.2363 (A2) 58-60 HRC– Materiał

Symbol		L											
DDP	DDHP	D	Land pow. robocza	R Max.	ø B H8	19	20	25	28	30	32	35	40
DDP8	DDHP8	8	3	4,0	1,60-3,20	*	*	*	*	*	*	*	*
DDP10	DDHP10	10	3	5,8	1,60-5,00	*	*	*	*	*	*	*	*
DDP13	DDHP13	13	3	8,0	3,00-7,00	*	*	*	*	*	*	*	*
DDP16	DDHP16	16	5	9,5	3,00-8,80	*	*	*	*	*	*	*	*
DDP20	DDHP20	20	5	11,9	3,00-11,00	*	*	*	*	*	*	*	*
DDP22	DDHP22	22	5	14,7	3,00-14,00	*	*	*	*	*	*	*	*
DDP25	DDHP25	25	5	17,4	3,00-17,00	*	*	*	*	*	*	*	*
DDP32	DDHP32	32	7	20,6	3,00-20,00	*	*	*	*	*	*	*	*
DDP38	DDHP38	38	7	27,0	3,00-26,00	*	*	*	*	*	*	*	*
DDP45	DDHP45	45	7	36,0	3,00-35,00	*	*	*	*	*	*	*	*
DDP50	DDHP50	50	7	41,0	3,00-40,00	*	*	*	*	*	*	*	*

Example order- Przykładowe zamówienie:

DDP10x 4,1x30

DDHP10x 4,1x30

How to order see page M.71 - Sposób zamawiania, patrz strona M.71

For dowel and location flats, please specify as shown on page M.67,M.68- Kołki ustalające i zabezpieczenie przed obrotem na życzenie (patrz strony M.67,M.68)

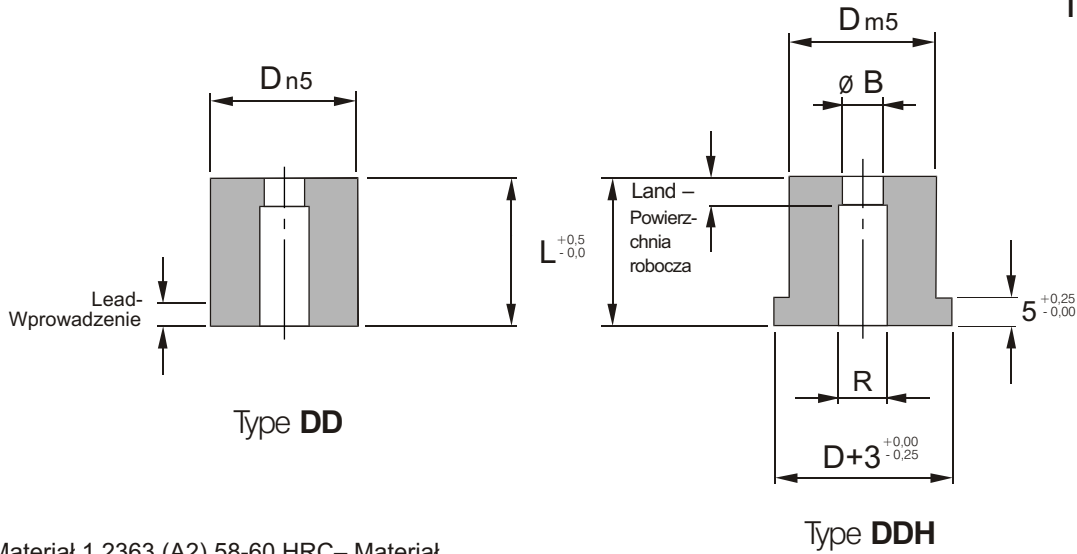

Materiał 1.2363 (A2) 58-60 HRC– Materiał

Symbol								D	Land pow. robocza	R Max.	L							
Headless Bez kołnierza				Headed Z kołnierzem							19	20	25	28	30	32	35	40
DDR8	DDF8	DDW8	DDL8	DDHR8	DDHF8	DDHW8	DDHL8	8	3	3,5	*	*	*	*	*	*	*	
DDR10	DDF10	DDW10	DDL10	DDHR10	DDHF10	DDHW10	DDHL10	10	3	5	*	*	*	*	*	*	*	
DDR13	DDF13	DDW13	DDL13	DDHR13	DDHF13	DDHW13	DDHL13	13	3	7	*	*	*	*	*	*	*	
DDR16	DDF16	DDW16	DDL16	DDHR16	DDHF16	DDHW16	DDHL16	16	5	9	*	*	*	*	*	*	*	
DDR20	DDF20	DDW20	DDL20	DDHR20	DDHF20	DDHW20	DDHL20	20	5	11	*	*	*	*	*	*	*	
DDR25	DDF25	DDW25	DDL25	DDHR25	DDHF25	DDHW25	DDHL25	25	5	16	*	*	*	*	*	*	*	
DDR32	DDF32	DDW32	DDL32	DDHR32	DDHF32	DDHW32	DDHL32	32	7	20	*	*	*	*	*	*	*	
DDR38	DDF38	DDW38	DDL38	DDHR38	DDHF38	DDHW38	DDHL38	38	7	27	*	*	*	*	*	*	*	
DDR45	DDF45	DDW45	DDL45	DDHR45	DDHF45	DDHW45	DDHL45	45	7	36		*	*	*	*	*	*	
DDR50	DDF50	DDW50	DDL50	DDHR50	DDHF50	DDHW50	DDHL50	50	7	41		*	*	*	*	*	*	

Example order- Przykładowe zamówienie:

DDR10x6,1x5,1x20

DDHW20x9,1x5,2x32

How to order see page M.71 - Sposób zamawiania, patrz strona M.71

For dowel and location flats, please specify as shown on page M.66 ,M.67

Kołki ustalające i zabezpieczenie przed obrotem na życzenie (patrz strony M.66, M.67)



Except where indicated the Y and Z dimensions are equal about centrelines
Jeżeli nie zaznaczono inaczej wymiary Y i Z są równe względem linii środkowych
90°

	NS1 	NS2 	NS3 	NS4 	
	NS5 	NS6 	NS7 	NS8 	
	NS9 	NS10 	NS11 	NS12 	
180°	NS13 	NS14 	NS15 	NS16 	0°
	NS17 	NS18 	NS19 Double Square 	NS20 T=No. of Teeth 	
Example die order Przykładowe zamówienie tulei MDHB16 NS4 25 Y=6,4 taper recess- wybieg stożkowy	NS21 	NS22 		Die view Widok z góry na matrycę 	

270°

To order dies please specify in addition to form dimensions:
-diameter
-length of land
-shaped, round or tapered recess
-overall length
Location flats if required please specify as shown on page M.66, M.67

Aby zamówić tuleje tnące, proszę obok wymiarów kształtu końcówki tnącej określić:
-średnicę zewnętrzną
-wysokość powierzchni roboczej matrycy
-wybieg kształtowy, cylindryczny lub stożkowy
-całkowitą wysokość matrycy
Zabezpieczenie przed obrotem na życzenie (patrz strony M.66, M.67)

Except where indicated the Y and Z dimensions are equal about centrelines
Jeżeli nie zaznaczono inaczej wymiary Y i Z są równe względem linii środkowych

90°

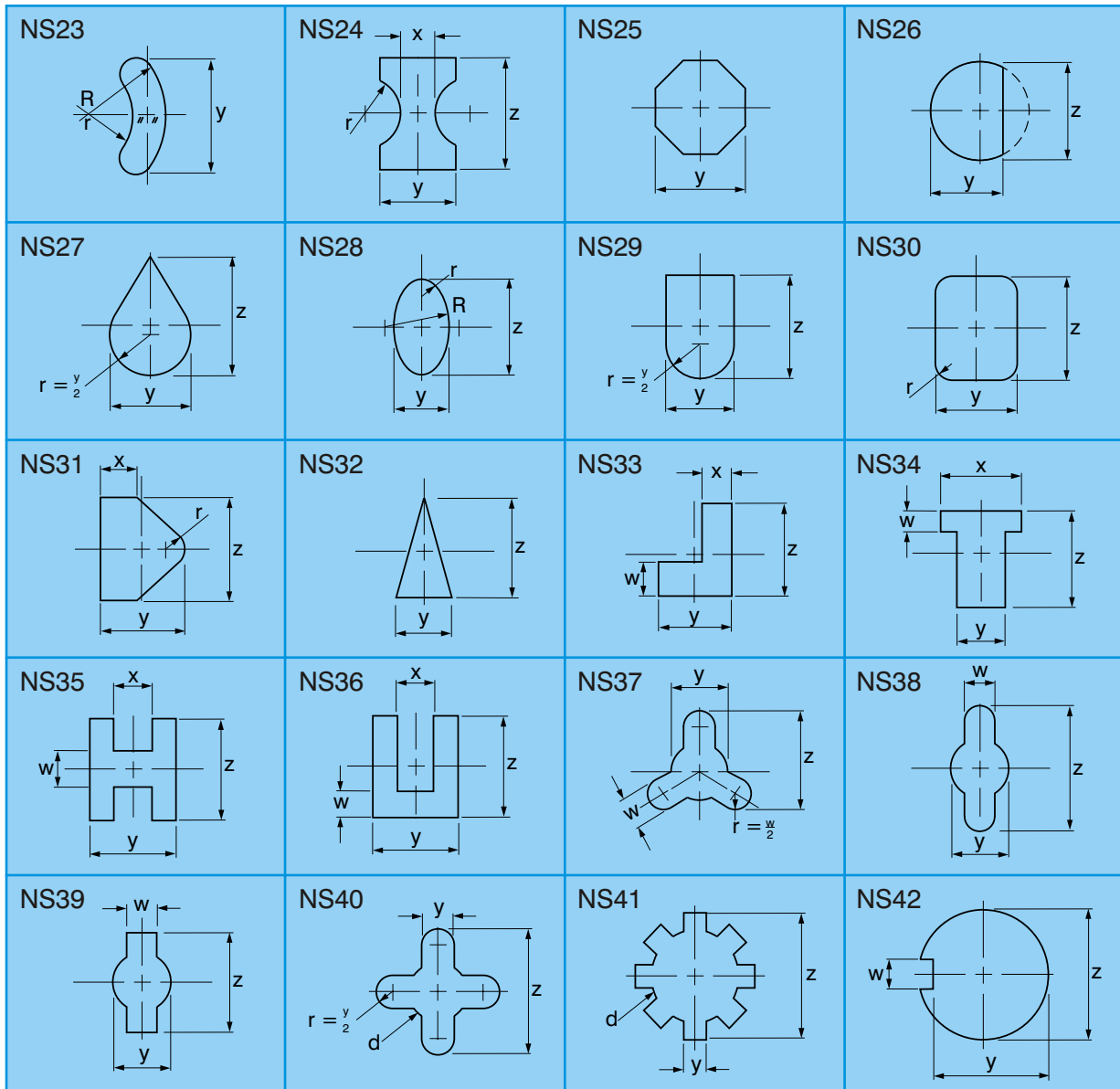

180°

0°

Punch view
Widok z góry na stempel

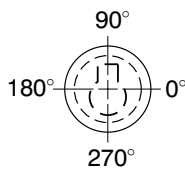

270°

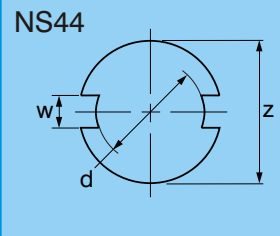
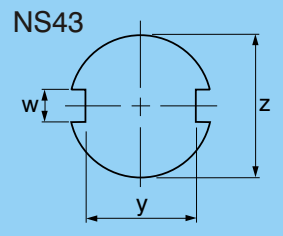

Example punch order
Przykładowe zamówienie stempli
6 off MIOB NS38 80
Z=7,4 Y=3,0 W=1,7

To order punches please specify in addition to form dimensions:

- shank diameter
- length of form excluding radius
- overall length

Location flats if required please specify as shown on page M.66, M.67

Aby zamówić stemple, proszę obok wymiarów kształtu końcówki tnącej określić:

- średnicę trzonu stempla
- długość końcówki tnącej bez promienia
- całkowitą długość stempla

Zabezpieczenie przed obrotem na życzenie (patrz strony M.66, M.67)

Die bushes

Tuleje tnące

Alternative land
Inna wysokość powierzchni roboczej

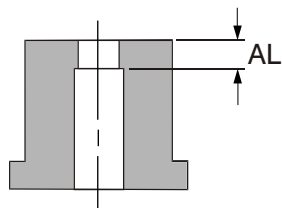

Specify land required- AL=
Proszę określić żadaną wysokość
powierzchni roboczej- AL=

Example order- Przykładowe zamówienie
MDHP10x6,1x30 AL=5,0
MDHT10x6,1x30 AL=8,0
MDHW32x15x20x30 AL=7,0

Die bushes

Tuleje tnące

Alternative head diameter
Inna średnica główki

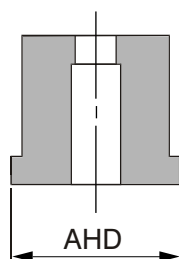

Specify head dia. required- AHD=
Proszę określić żadaną średnicę
główki- AHD=

Example order- Przykładowe zamówienie
MDHP10x6,1x30 AHD=16,0
MDHT10x6,1x30 AHD=14,0
MDHW32x15x20x30 AHD=33,0

Die bushes

Tuleje tnące

Alternative thickness head
Inna grubość główki

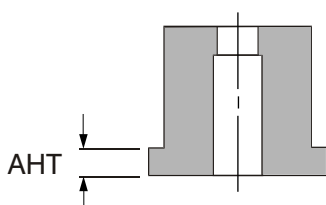

Specify head thick. required- ATH=
Proszę określić żadaną grubość
główki- ATH=

Example order- Przykładowe zamówienie
MDHP10x6,1x30 ATH=8,0
MDHT10x6,1x30 ATH=8,0
MDHW32x15x20x30 ATH=15,0

Die bushes

Tuleje tnące

Alternative body diameter
Inna średnica zewnętrzna

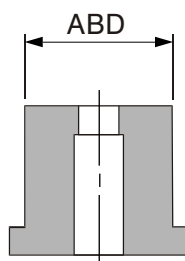

Specify body dia. required- ABD=
Proszę określić żadaną średnicę
zewnętrzną- ABD=

Example order- Przykładowe zamówienie
MDHP11ABDx6,1x30
MDHT11ABDx6,1x30
MDHW33ABDx15x20x30

Punches

Stemple

Code BF1mm

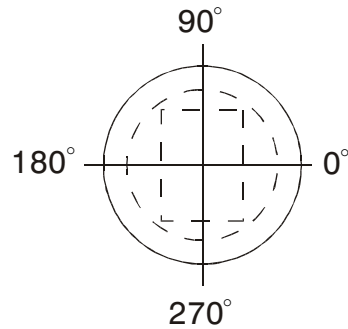
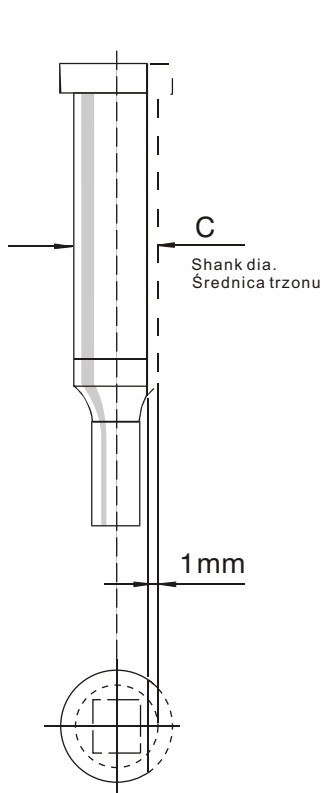

Body flats supplied as standard at 0° unless otherwise specified

O ile nie określono inaczej, płaszczyzny umiejscowione są na pozycji 0°

Body flats = C-1mm

Płaszczyzna ustalająca= C-1mm

Example order

Przykładowe zamówienie

MR10D 4x8x90 Bf1

Die & stripper bushes

Tuleje tnące i zdzierające

Code BF1mm

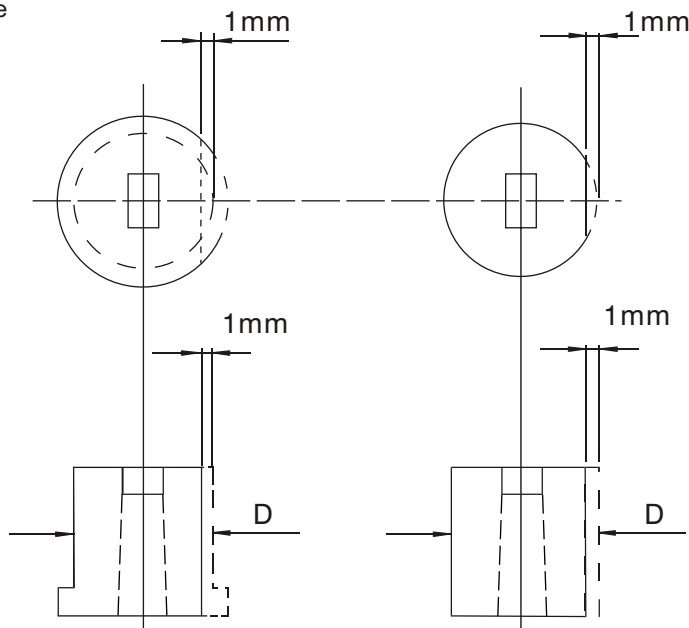

Alternative

Opcje

BF1=1mm (standard)

BF*= specyfy

BF*= proszę określić

Body flat = D-1mm

Płaszczyzna ustalająca = D-1mm

Example order

Przykładowe zamówienie

MDW20 8x4x25 Bf1

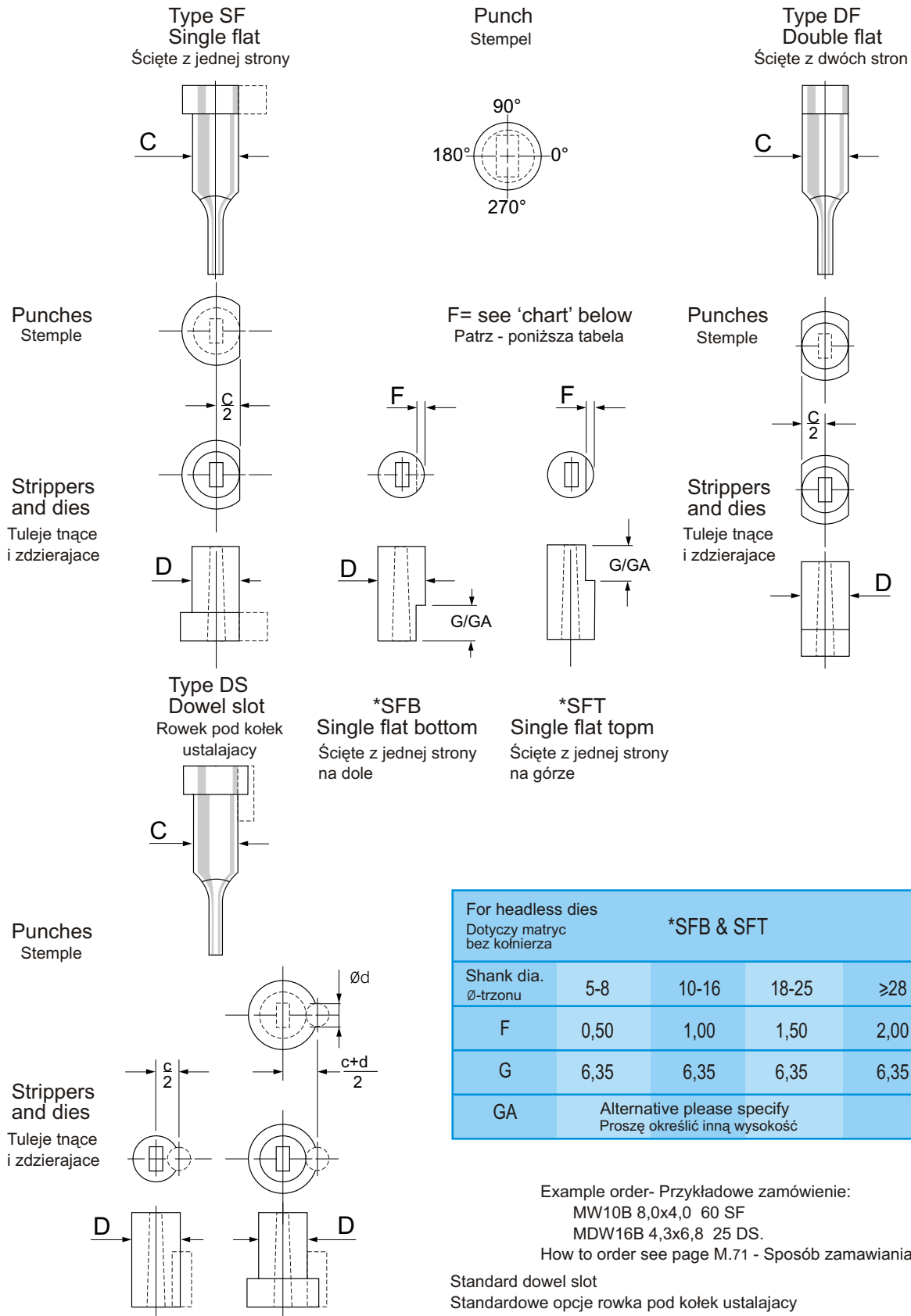

Example order- Przykładowe zamówienie:

MW10B 8,0x4,0 60 SF

MDW16B 4,3x6,8 25 DS.

How to order see page M.71 - Sposób zamawiania, patrz strona M.71

Standard dowel slot

Standardowe opcje rowka pod kołek ustalający

DS3=3mm dowel -DS3= kołek 3mm

DS4=4mm dowel -DS4= kołek 4mm

DS5=5mm dowel -DS5= kołek 5mm

DS6=6mm dowel -DS6= kołek 6mm

Symbol	External dimension -Wymiary zewnętrzne Nominal dimensions in [μm] -Tolerancje w [μm]							Internal dimension -Wymiary wewnętrzne Nominal dimensions in [μm] -Tolerancje w [μm]					
	1 \geq 3	3 \geq 6	6 \geq 10	10 \geq 18	18 \geq 30	31 \geq 50		1 \geq 3	3 \geq 6	6 \geq 10	10 \geq 18	18 \geq 30	31 \geq 50
e8	-14 -28	-20 -38	-25 -47	-32 -59	-40 -73	-50 -89	E8	+28 +14	+38 +20	+47 +25	+59 +32	+73 +40	+89 +50
g5	-2 -6	-4 -9	-5 -11	-6 -14	-7 -16	-9 -20	F7	+16 +6	+22 +10+	+28 13	+34 +16+	+41 +20	+50 +25
g6	-2 -8	-4 -12	-5 -14	-6 -17	-7 -20	-9 -25	G6	+8 +2	+12 +4	+14 +5	+17 +6	+20 +7	+25 +9
h3	0 -2	0 -2,5	0 -2,5	0 -3	0 -4	0 -4	G7	+12 +2	+16 +4	+20 +5	+24 +6	+28 +7	+34 +9
h5	0 -4	0 -5	0 -6	0 -8	0 -9	0 -11	H5	+4 0	+5 0	+6 0	+8 0	+9 0	+11 0
h6	0 -6	0 -8	0 -9	0 -11	0 -13	0 -16	H6	+6 0	+8 0	+9 0	+11 0	+13 0	+16 0
h8	0 -14	0 -18	0 -22	0 -27	0 -33	0 -39	H7	+10 0	+12 0	+15 0	+18 0	+21 0	+25 0
h9	0 -25	0 -30	0 -36	0 -43	0 -52	0 -62	H8	+14 0	+18 0	+22 0	+27 0	+33 0	+39 0
h10	0 -40	0 -48	0 -58	0 -70	0 -84	0 -100	H9	+25 0	+30 0	+36 0	+43 0	+52 0	+62 0
h11	0 -60	0 -75	0 -90	0 -110	0 -130	0 -160	H10	+40 0	+48 0	+58 0	+70 0	+84 0	+100 0
j6	+4 -2	+6 -2	+7 -2	+8 -3	+9 -4	+11 -5	H11	+60 0	+75 0	+90 0	+106 0	+130 0	+160 0
js6	+3 -3	+4 -4	+4,5 -4,5	+5,5 -5,5	+6,5 -6,5	+8 -8	H12	+100 0	+120 0	+150 0	+180 0	+210 0	+250 0
js7	+5 -5	+6 -6	+7,5 -7,5	+9 -9	+10,5 -10,5	+12,5 -12,5	J6	+2 -4	+5 -3	+5 -4	+6 -5	+8 -5	+10 -6
js8	+7 -7	+9 -9	+11 -11	+13,5 -13,5	+16,5 -16,5	+19,5 -19,5	J7	+4 -6	+6 -6	+8 -7	+10 -8	+12 -9	+14 -11
js9	+12,5 -12,5	+15 -15	+18 -18	+21,5 -21,5	+26 -26	+31 -31	JS5	+2 -2	+2,5 -2,5	+3 -3	+4 -4	+4,5 -4,5	+5,5 -5,5
js13	+70 -70	+90 -90	+110 -110	+135 -135	+165 -165	+195 -195	K6	0 -6	+2 -6	+2 -7	+2 -9	+2 -11	+3 -13
js14	+125 -125	+150 -150	+180 -180	+215 -215	+260 -260	+310 -310	K7	0 -10	+3 -9	+5 -10	+6 -12	+6 -15	+7 -18
k6	+6 0	+9 +1	+10 +1	+12 +1	+15 +2	+18 +2	K8	0 -14	+5 -13	+6 -16	+8 -19	+10 -23	+12 -27
k7	+10 0	+13 +1	+16 +1	+19 +1	+23 +2	+27 +2	M6	-2 -8	-1 -9	-3 -12	-4 -15	-4 -17	-4 -20
m4	+5 +2	+8 +4	+10 +6	+12 +7	+14 +8	+16 +9	M7	-2 -12	0 -12	0 -15	0 -18	0 -21	0 -25
m5	+6 +2	+9 +4	+12 +6	+15 +7	+17 +8	+20 +9	N7	-4 -14	-4 -16	-4 -19	-5 -23	-7 -28	-8 -33
n6	+10 +4	+16 +8	+19 +10	+23 +12	+28 +15	+33 +17	P7	-6 -16	-8 -20	-9 -24	-11 -29	-14 -35	-17 -42

As an ongoing development and expansion of our product range we reserve the right to amend this catalog without notice. 2002
Zastrzegamy sobie prawo do poprawek niniejszego katalogu bez uprzedzenia. 2002

Ball lock angle tool
Narzędzie z końcówką wygiętą



Symbol ...818038

Ball lock straight tool
Narzędzie z końcówką prostą



Symbol ...818046

Ball lock threaded tool
Narzędzie z końcówką gwintowaną



Symbol ...269999

Example order- Przykładowe zamówienie:
6 off 818046

I. Punches and pilots

When ordering please specify:

- a) - punch style and point shape - shown on each page, eg. MT, MR, MEW, ...
- b) - shank diameter "C"
- c) - point length, eg. type A, B, C, D, AL.
- d) - point shape dimensions
- e) - total length of punch
- f) - location flats if necessary- see page M.66
- g) - PVD coating-see page M.3

Example order:

MT6C-4,25x80	MER13D-12,00x10,00x100 SF TiCN
a) MT	a) MER
b) C=6	b) C=13
c) 19 (type C)	c) 25 (type D)
d) 4,25	d) 12,00x10,00
e) L=80	e) L=100
	f) SF
	g) TiCN

Example order shown also on each page

I. Stemple i piloty

Przy zamówieniu należy określić:

- a) - rodzaj stempla i kształt części roboczej- podany na każdej stronie np. MT, MR, MEW, ...
- b) - średnicę części prowadzącej "C"
- c) - długość części roboczej, np. (typ A, B, C, D, AL)
- d) - wymiary części roboczej
- e) - długość całkowitą stempla
- f) - ewentualne zabezpieczenie przed obrotem- patrz str. M.66
- g) - powłoka PVD- patrz str. M.3

Przykładowe zamówienia:

MT6C-4,25x80	MER13D-12,00x10,00x100 SF TiCN
a) MT	a) MER
b) C=6	b) C=13
c) 19 (type C)	c) 25 (typ D)
d) 4,25	d) 12,00x10,00
e) L=80	e) L=100
	f) SF
	g) TiCN

Przykładowe zamówienie podano także na każdej stronie

II. Die bushes

When ordering please specify:

- a) - die bush style and land shape, eg. MDT, MDHW, MDHP, ...
- b) - body diameter
- c) - shape dimensions
- d) - total length
- e) - location flats if necessary- see page M.66
- f) - PVD coating- see page M.3

Example order:

MDT16-8,40x25	MDHW25-12,30x10,30x32 SF90⁰ TiN
a) MDT	a) MDHW
b) D=16	b) D=25
c) 8,40	c)12,30x10,30
d) 25	d) 32
	e) SF90 ⁰
	f) TiN

Example order shown also on each page

II. Tulejki tnące

Przy zamówieniu należy określić:

- a) - rodzaj matrycy i kształt części roboczej, np. MDT, MDHW, MDHP, ...
- b) - średnicę zewnętrzną matrycy
- c) - wymiary kształtu części roboczej
- d) - wysokość całkowitą
- e) - ewentualne zabezpieczenie przed obrotem- patrz str. M.66
- f) - powłoka PVD- patrz str. M.3

Przykładowe zamówienie:

MDT16-8,40x25	MDHW25-12,30x10,30x32 SF90⁰ TiN
a) MDT	a) MDHW
b) D=16	b) D=25
c) 8,40	c)12,30x10,30
d) 25	d) 32
	e) SF90 ⁰
	f) TiN

Przykładowe zamówienie podano także na każdej stronie

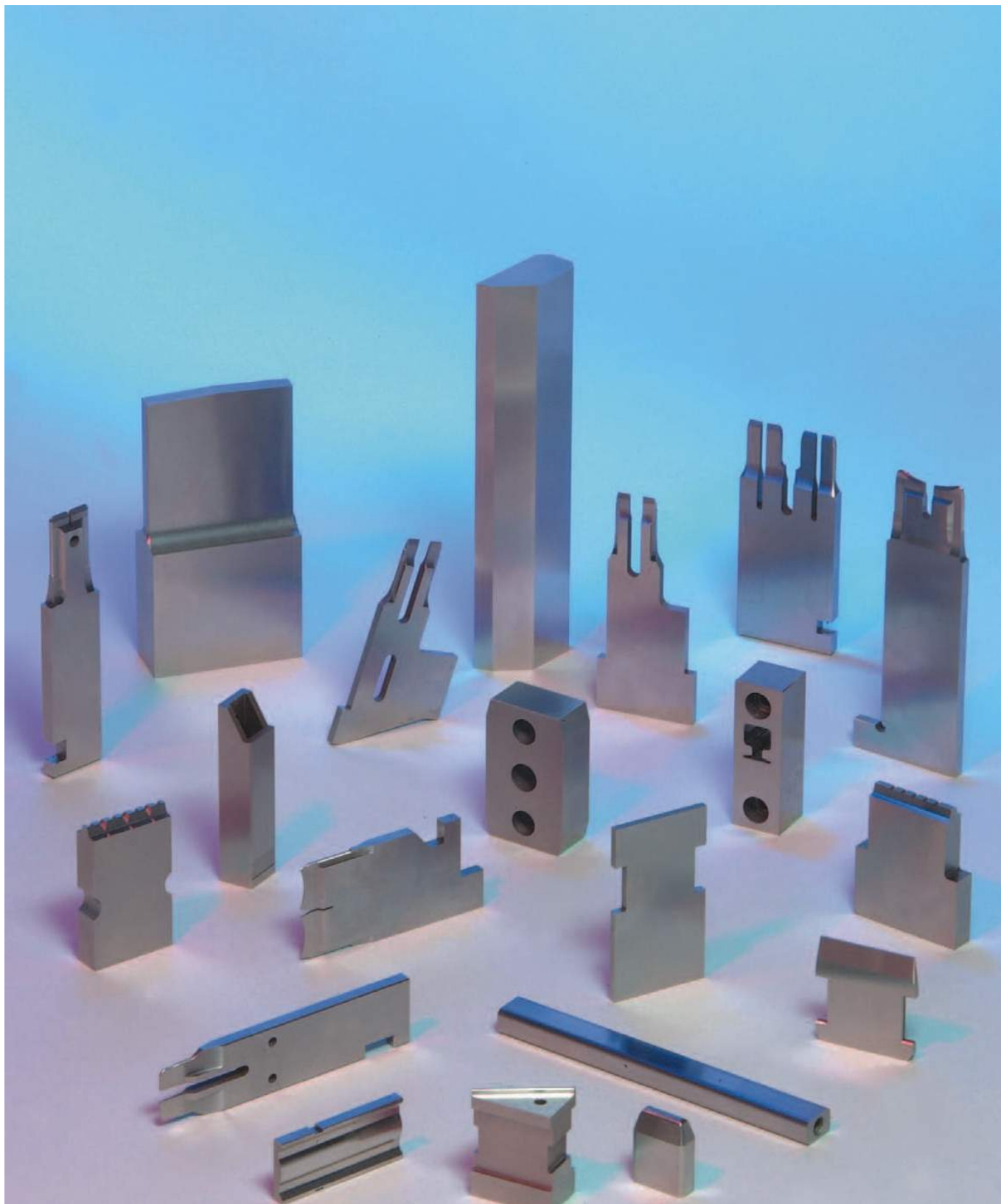

Precision Ground Blade Punches to your Specification
Precyzyjne stemple nożowe według dokumentacji klienta